

Modular cable solutions

High and extra high voltage

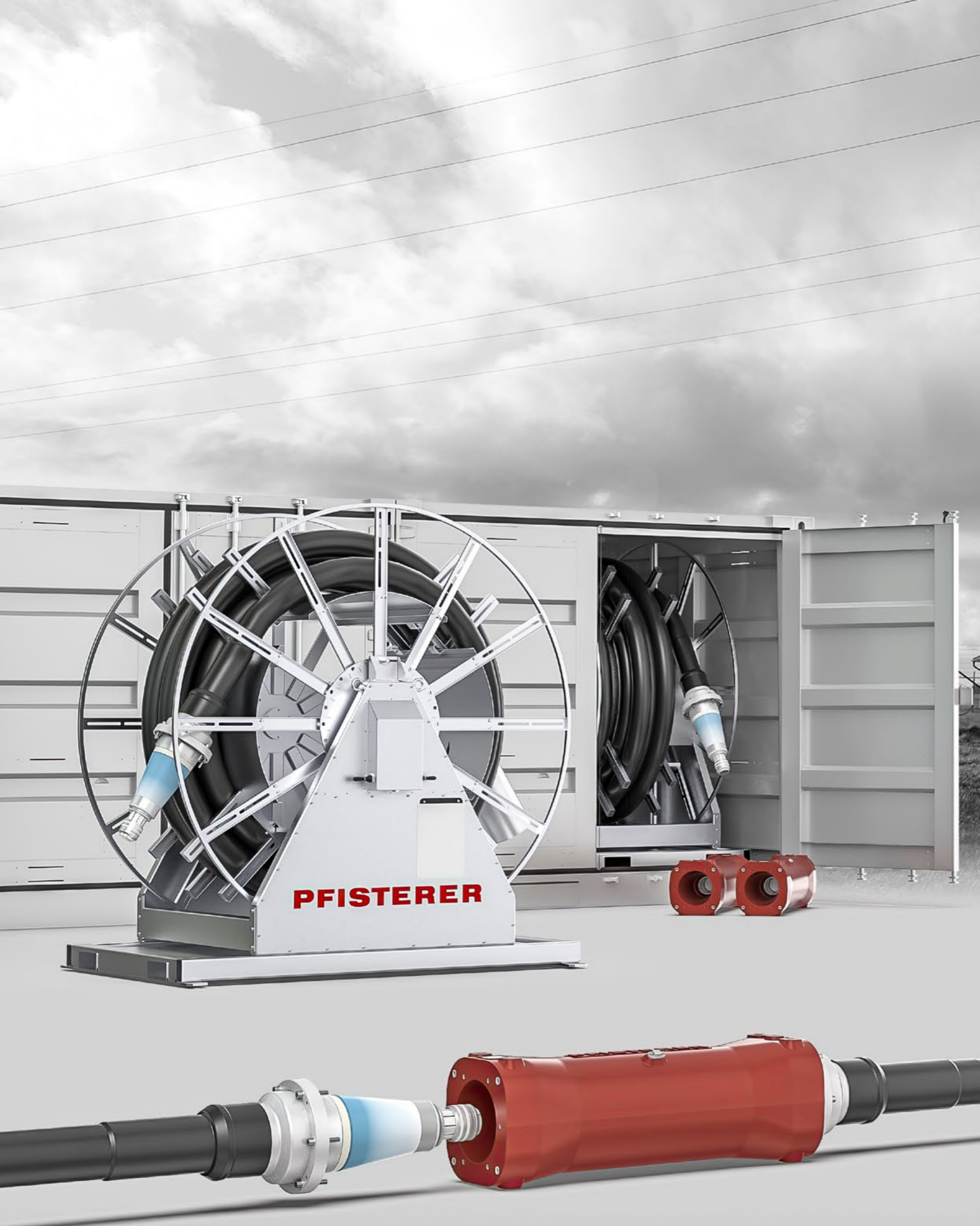

Catalog part 3 / 3



WELCOME!

Every time with or without electricity counts. So does the profitability of investments in the long term. Both aspects determine the aspiration and daily routine of PFISTERER as your high-performance partner for high and extra-high voltage grids. The accessories portfolio in this third part catalog serves these grids in purpose of lifelong efficient power flow on land and sea:

- The CONNEX product range puts comprehensive user-friendliness in practise with the widest range of advanced plug-in components – cable connectors, bushings, various joint types and now also outdoor cable terminations – as well as practical tools for installation, protection etc.
- Quick-deploy solutions enable optimum operational readiness for plannable work and surprise deployments. Tailor-made for specified applications. Available in three different configuration levels. Consisting of CONNEX components and other proven products from the full PFISTERER offering.

This variety combines fundamental component and system properties for resilient grid operation: Wide areas of applications. Configurable as required for flexible use on all XLPE and EPR cables as well as transformers and gas-insulated switchgear. Easy to install during initial and subsequent installations. Safe, robust and reliable in lifelong use.

So that grid builders and operators can act quickly, leanly and safely at all times: During installation, change of use and dismantling. During grid operation in sensitive environments. During transportation and in storage.

You can find interesting facts about the quality and origin of PFISTERER accessories at the start of the first section of this catalog, followed by detailed product information in sections 1 to 3.

Application outlooks in section 4 show you possible uses of PFISTERER solutions from all three accessories catalog parts: At the transition from overhead lines to cables. In underground and above-ground cable routes on land. In offshore wind turbines and substations. At and between gas-insulated switchgear as well as power and distribution transformers.

Would you like more information? Send your request by email or give us a call: Contact details are on the last outer page. PFISTERER specialists for interface solutions will be happy to answer your questions.



Now, as you turn the pages, you will gain rewarding insights into numerous means and possibilities of shaping solutions for your needs, in a way that makes optimum use of existing assets and paves the way for future-proof development. With foresight that pays off.

More advanced PFISTERER interface solutions for your high and extra high voltage applications appear in:

Catalog part 1 focusing on pluggable CONNEX components for transformers and GIS. They enable flexible, interchangeable connection types in all practically relevant configurations – without intervention inside the equipment, thanks to the highly versatile connection system.

Catalog part 2 with the entire PFISTERER portfolio of modern and conventional terminations, as well as connection joints and link boxes. They can be custom-fit combined and configured for numerous interface applications from overhead lines, in cable routes and in substations.

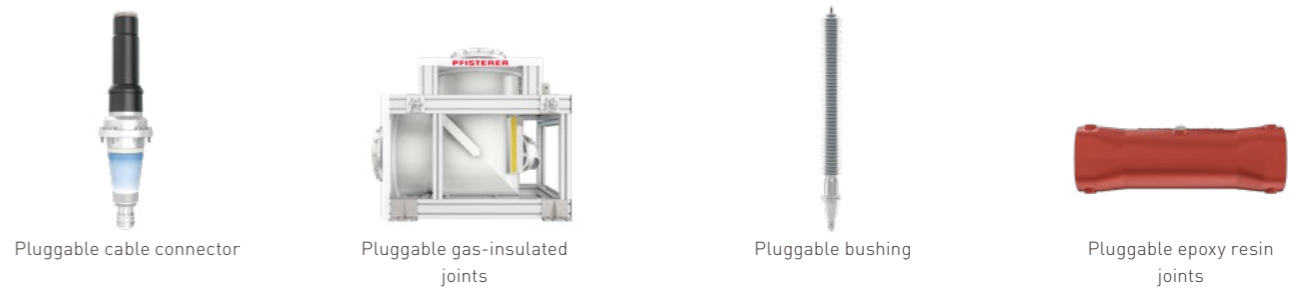
Contents

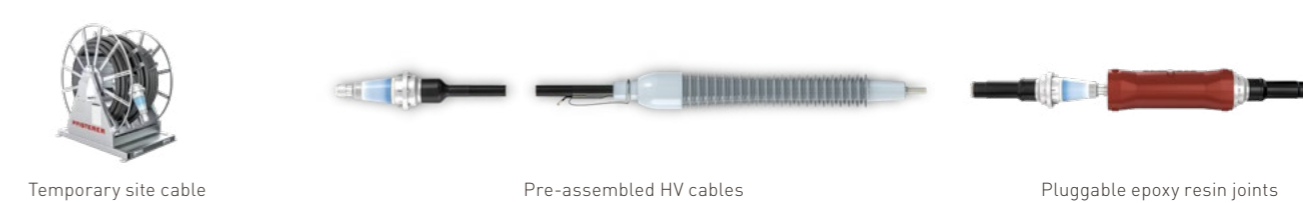
1	Cable connections and joints	Pages 6 - 16
1.1	CONNEX pluggable cable connector.....	08
1.2	CONNEX pluggable gas-insulated joints.....	10
1.3	CONNEX pluggable bushing.....	13
1.4	CONNEX pluggable epoxy resin joints	14
		
2	Complementary tools for safety, protection and ease of handling	Pages 17 - 21
2.1	Useful tools for CONNEX components	16
2.2	Extra tools for CONNEX gas-insulated joints	18
		
3	Quick-Deploy System Solutions	Pages 22 - 25
3.1	Basic systems: Terminations on cables.....	20
3.2	Plus systems: Extensions with joints.....	22
3.3	Advanced systems: Complete solutions	24
		
4	Application outlooks	Pages 26 - 33
4.1	Diverse accessories for lifelong efficiency in use	28
4.2	Versatile repair solution for different cable types	30
4.3	Modular offshore solutions for wind turbines and platforms.....	32
5	Services	Pages 34 - 35
5.1	Installation: Service, training, instruction.....	34
5.2	Engineering	35

 This product catalog contains a representative selection of the most prevalent products from the PFISTERER range. Additional versions and custom applications can be available on request. Products described as optional complementary tools are not included in the standard scope of supply and have to be ordered separately if required.

Solutions for high and extra high voltage grids. Tested quality from PFISTERER.

The following pages provide detailed information about the PFISTERER products in this catalog part:

- CONNEX connecting and jointing components with plug-in technology for currently up to 550 kV
- Practical tools for installation, protection, etc.
- Quick-deploy systems in three configuration levels for testing, construction uses and much more

PFISTERER solutions represent technical progress based on proven technologies and tested designs.

Designed with know-how gained from 100 years of experience in the transmission of high currents and insulation of high voltages.

Developed, manufactured and assembled to the highest quality standards using state-of-the-art processes at PFISTERER sites in Europe, certified to ISO standards for quality and environmental management as well as occupational health and safety, and also qualified under various well-known industry standards and special requirements of many customers from around the world.

Solutions from PFISTERER for high and extra high voltage are type-tested and individually tested based on various requirements of international standards (IEC, IEEE, etc.). Testing is carried out at PFISTERER high voltage lab and in end-of-line test fields, or at recognized external test institutes.

PFISTERER accessories also successfully complete system tests with various HV and EHV cables according to demanding customer specifications that exceed standard requirements. In addition, they prove their performance capability in prequalification tests lasting several months, which simulate decades of operation under real operating conditions. These additional tests are performed in cooperation with users and cable manufacturers, either internally or externally, in the laboratory or in the field, depending on testing requirements.

1.1 CONNEX pluggable cable connector

1.1

The CONNEX cable connector is variably configurable and so can be used for any XLPE or EPR cable. Its advanced contact system technology offers mechanical and electrical reliability as well as a high degree of flexibility: After it has been prefitted to the cable, for final installation the connector simply plugs into CONNEX components of the same or compatible size, such as various CONNEX joints (see sections 1.2 and 1.4), the CONNEX outdoor cable termination (2.1), or CONNEX sockets that are permanently installed in transformers and GIS (see catalog part 1).

In all these applications, the cable connector can be separated again and connected to the same or another suitable CONNEX interface. The cable connection is offshore certified and suitable for low temperature (optional).



At a glance

- Considerably reduced installation time thanks to plug-in technology
- Horizontal, vertical and inclined arrangement possible
- Compact installation dimensions
- Connector is separable and can be swapped at any time
- Touch-safe, floodable and maintenance free
- Fully dry insulated, therefore:
 - No handling of liquid or gaseous insulating materials during installation
 - No leakage or environmental risks
- Routine tested before delivery

CONNEX pluggable cable connector – the right connector for every cable

PFISTERER accessories are configured cable-specifically. The blue QR code at the bottom right takes you to all relevant parameters for the CONNEX cable connector.

The most important parameters for the CONNEX cable connector you can already see here:

- Voltage level (kV): _____
Defines the size of the cable connector
- Application: Indoor
Outdoor Low temperature Offshore
Defines the complementary tools
- Link box connection: Yes No
If yes, diameter of the bonding cable (mm): _____
- Diameter over conductor in mm: _____
Defines the contact system of the cable connector
- Diameter over insulation in mm: _____
Defines the complementary tools
- Type of cable screen
- Cross-section of the cable screen: _____
Defines the insulating section of the cable connector
- Type of armoring
(wire or tape armoring): _____
Defines the complementary tools

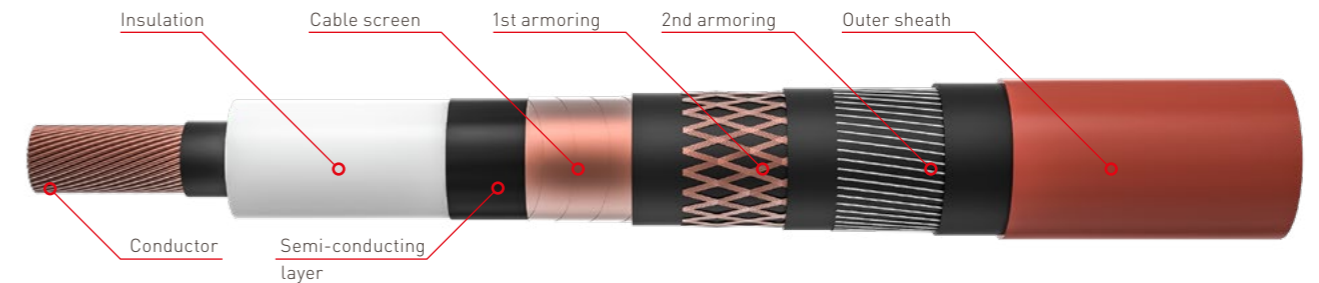

CONNEX pluggable cable connector

Size	Highest voltage U_m [kV]	Nominal voltage U_n [kV]	Conductor to ground voltage U_0 [kV]	Nominal current ¹ I_n [A]	Conductor cross- section ^{2,3} [mm ²] RM	Conductor diameter ³ [mm] RM	Diameter over insulation [mm]	Article no. ⁴ [variants]
4	72.5	60 - 69	36	2,500	95 - 2000	9.3 - 55.9	33.0 - 78.5	849 999 999 XXXX
5-S	145	132 - 138	76	2,500	95 - 2000	9.3 - 55.9	36.5 - 76.0	859 999 999 XXXX
6	145	132 - 138	76	2,500	95 - 2500	9.3 - 65.0	36.0 - 113.5	866 999 999 XXXX
6	170	150 - 161	87	2,500	95 - 2500	9.3 - 65.0	36.0 - 113.5	866 999 999 XXXX
6-S	245	220 - 230	127	2,500	95 - 2500	9.3 - 65.0	36.0 - 113.5	866 999 999 XXXX
7	300	275 - 287	160	4,000	500 - 3000	24.8 - 72.5	75.0 - 131.0	877 999 999 XXXX
7-S	362	330 - 345	190	4,000	500 - 3000	24.8 - 72.5	75.0 - 131.0	877 999 999 XXXX
8	420	380 - 400	220	4,000	500 - 3000	24.8 - 72.5	65.0 - 144.0	889 999 999 XXXX
9	550	500	290	4,000	500 - 3000	24.8 - 72.5	65.0 - 144.0	899 999 999 XXXX

You can find the configuration form for the CONNEX cable connector on our website under downloads.

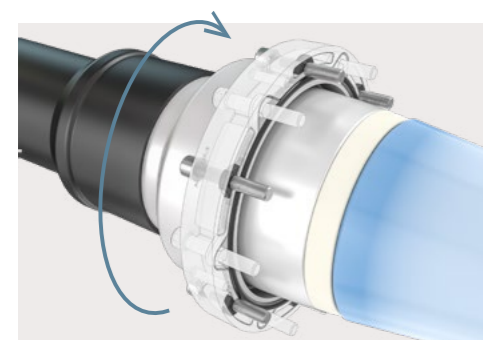

Rotatable bell flange

The rotatable bell flange enables pre-assembly, for example, since the cable does not have to be rotated during installation.

- I_n for cable accessories (depending on cable cross-section).
- The cross-section range is an indicative value only. The range can only be achieved if the min./max. diameter over conductor and the min./max. diameter over insulation are observed.
- Values shown in table are for round multiwire (RM) conductors. Values on request for round solid (RE) and round fine stranded (RF) as well as enameled wires conductors.
- Individual variant number specified with a configurator based on cable data.

Example illustration: CONNEX size 6 cable connecting system

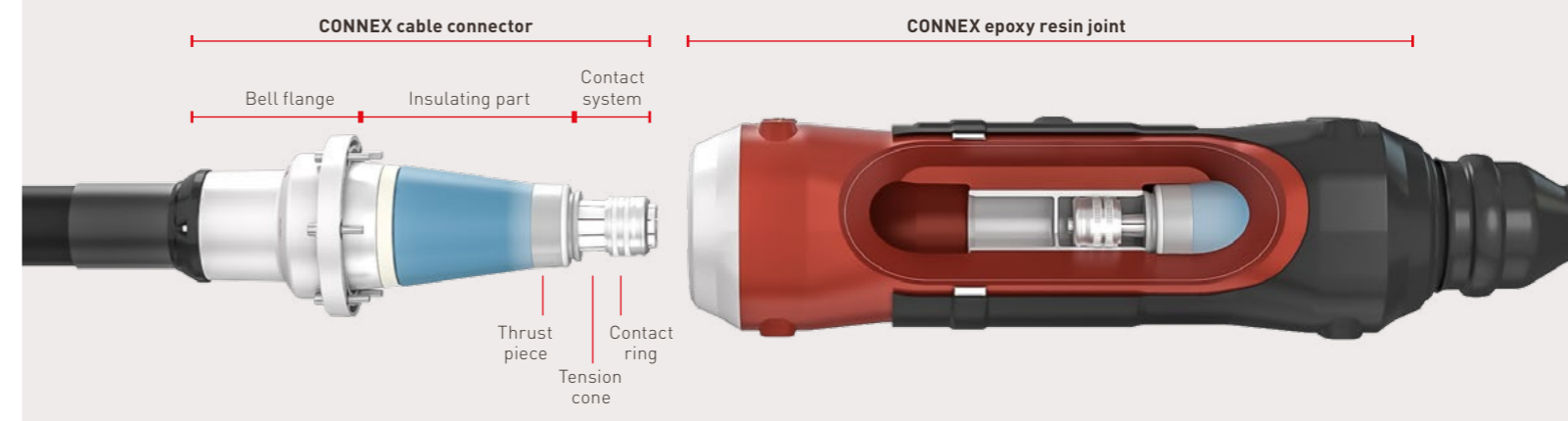

1.2 CONNEX pluggable gas-insulated joints

Safe high voltage joints can be realized efficiently and flexibly using the high-performance CONNEX joint family with either conventional or alternative gas insulation.

There are versions designed for straight or right-angled arrangements as well as branch joints – all with the same advantages for versatile use: Every CONNEX joint can connect different cable types and cross-sections. Thanks to a very high degree of pre-assembly and plug connector technology, all these joints are ready to use for the rapid final installation of

- diverse pluggable CONNEX components and complementary tools, for example:
- CONNEX cable connectors for all types of XLPE and EPR cable (see section 1.1)
 - CONNEX bushings for connecting bare conductors (1.3)
 - CONNEX dummy plugs for voltage-proof sealing of unused connection points (2.2)

For numerous applications, whether short-term or for longer periods:

- Formation, extension and diversion of cable runs
- Type testing and on-site testing of cable systems and equipment
- Supplying equipment on cables from overhead lines, etc.

Practical tools make joints safe and easy to use (for details see 2.3):

- Cable supports with cable clamps for reliable functioning and safe operation
- Fastening brackets as basic tools for various safety and handling purposes
- Transport casters and sets for moving the joints without cables plugged in

At a glance

- Proven modern joint family for high and extra high voltages
- Insulated with either conventional or alternative gas
- Diverse types for various joints: straight, right-angled, branch joint
- Different cable types and cross-sections can be connected with each joint
- Easy to use thanks to plug-in installation and very high degree of pre-assembly
- For fast plug-in connection of various CONNEX products: Cable connector (1.1), bushing (1.3), dummy plug (2.2) etc.
- Connected parts are separable and can be swapped at any time
- On request, different connection sizes can be combined in one joint
- Standard features: Bursting disk for pressure protection, gas density monitor with activatable remote monitoring
- Metal-enclosed and fully insulated
- Routine tested before delivery



CONNEX gas-insulated connection joint

The gas-insulated CONNEX connection joint for up to 550 kV is a proven all-rounder: It efficiently and reliably joins XLPE and EPR cables of the same or different types with a plug-in connection, and creates voltage-proof terminations for cable testing.

Application

- Pluggable connection of two cable sections
- Cables with different cross-sections can also be connected
- Electrical cable testing

CONNEX gas-insulated connection joint

Size	Highest voltage U_m [kV]	Nominal current I_n [A]	Individual testing AC 1 min [kV]	BIL* [kV]	Article no.
4	72.5	2500	140	325	827 049 101
5-S	145	2500	275	650	827 052 101
6	170	2500	325	750	827 053 101
6-S	245	2500	460	1050	827 059 101
7-S	362	4000	460	1175	827 078 011
8	420	4000	440	1425	827 076 021
9	550	4000	580	1550	827 076 031



CONNEX gas-insulated T-joint

The gas-insulated CONNEX T-joint for up to 245 kV can be used to neatly branch off from one larger cable to one or two smaller cables. If one connection point remains unused, it can be easily sealed using a voltage-proof CONNEX dummy plug (more in section 2.2).

Application

- Branch off from one XLPE or EPR cable to one or two XLPE or EPR cables
- If one connection point is unused, it has to be sealed using a voltage-proof dummy plug

CONNEX gas-insulated T-joint

Size	Highest voltage U_m [kV]	Nominal current I_n [A]	Individual testing AC 1 min [kV]	BIL* [kV]	Article no.
4	72.5	2500	140	325	827 062 101
5-S	145	2500	275	650	827 047 201
6	170	2500	325	750	827 057 101
6S	245	2500	460	1050	827 063 101

* Lightning impulse [withstand voltage]

1.2 CONNEX pluggable gas-insulated joints

CONNEX gas-insulated elbow joint

With two connection points arranged at right angles, the gas-insulated CONNEX elbow joint for up to 245 kV enables space-saving optimized cable routing in confined spaces and across multiple levels. Combined with a vertically plugged in CONNEX bushing, the elbow joint is a fast and mobile solution for temporarily supplying equipment on cables from overhead lines, for example during revisions or repairs, or also for occasional electrical equipment testing.

Application

- Pluggable connection of two cable sections
- Pluggable connection for the transition from cable to bare conductor

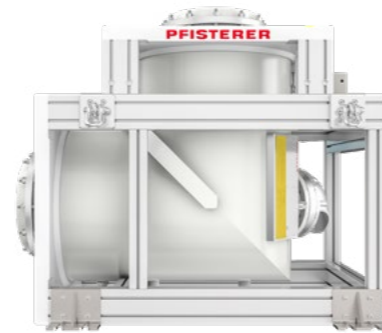

CONNEX gas-insulated elbow joint

Size	Highest voltage U_m [kV]	Nominal current ¹ I_n [A]	Individual testing AC 1 min [kV]	BIL* [kV]	Article no.
5-S	145	2500	275	650	827 077 010
6	170	2500	325	750	827 077 002
6S	245	2500	460	1050	827 077 003

* Lightning impulse (withstand voltage)

Example illustration:

Component arrangement with combined use of pluggable CONNEX bushing (top) and pluggable CONNEX cable connector (bottom) on the CONNEX elbow joint

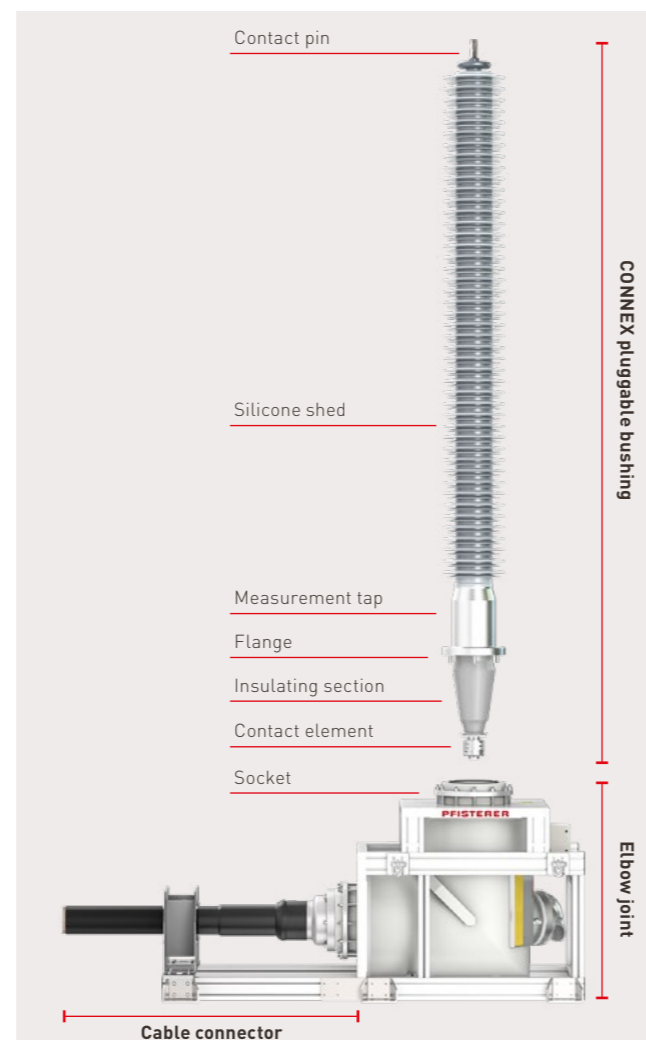

1.3 CONNEX pluggable bushing



The dry-insulated CONNEX bushing with advanced plug connector technology offers lifelong very high user-friendliness:

Mounted vertically on a CONNEX elbow joint (illustration to the left below), it forms a practical interface for the transition from overhead line or busbar to cable – also as a mobile interim solution and for occasional testing. In addition, the bushing can be used for connecting transformers to bare conductors (see catalog part 1). In each application, the bushing is efficiently installed by plugging it into CONNEX connection elements, which are permanently integrated into CONNEX joints and transformers. The bushing is installed and removed without handling gaseous or liquid insulating materials, without intervening in the inner workings of the joint or equipment. At any time, the bushing can be swapped for a CONNEX cable connector of the same or compatible size. The pluggable CONNEX bushing has been in the PFISTERER product range for over 20 years.

At a glance

- For efficient flexible connection of bare HV conductors in many applications:
- Can be plugged into CONNEX elbow joints for mobile interim solutions and occasional tests
- For permanent or temporary connections of transformers (see catalog part 1)
- Dry, solid-insulated and with plug connector technology, therefore:
- Installation without handling gaseous or liquid insulating materials, without intervention inside the CONNEX joint or transformer
- Swappable with other CONNEX components, e.g. cable connector
- Can be plugged multiple times – simplified transportation and handling
- Water and dirt repellent silicone rubber insulator sheds
- Maintenance-free, no leakage or environmental risks, explosion-proof
- With voltage tap for measuring the loss factor ($\tan \delta$) and capacitance
- Routine tested before delivery

CONNEX pluggable bushing

Size	Standard	Type	Highest voltage U_m [kV]	Nominal current I_n [A]	Length from flange [mm]	Arcing distance [mm]	Creepage distance [mm]	Weight [kg]	Article no.
4	IEC	RIS	72.5	2000	960	600	2248	48	828 184 001
5-S	IEC	RIP	145	1250	1600	1300	4495	85	828 186 012
6	IEC	RIP	145	1250	1665	1250	4495	108	828 187 020
6	IEC	RIP	170	1250	1915	1500	5270	125	828 187 019
6-S	IEC	RIP	245	1250	2735	2300	7595	166	828 192 001
6	IEEE	RIS	138	1250	1665	1260	4836	108	828 187 021
6	IEEE	RIS	161	1250	1915	1500	5788	125	828 187 022

1.4 CONNEX pluggable epoxy resin joints

1.4

With its compact design, the CONNEX epoxy resin joint for up to 170 kV combines many strengths for versatile applications – even under extreme conditions:

Thanks to solid insulation and plug connector technology with a very high degree of pre-assembly, the CONNEX epoxy resin joint is immediately ready for final installation by plugging in the cables – without any laborious handling of gaseous or liquid insulating materials.

XLPE and EPR cables of any type equipped with CONNEX cable connectors (see section 1.1) can be plugged in and combined in a joint, whether the same or different cable types and cross-sections, rigid or highly flexible cables.

The CONNEX joint always creates all-round safe and flexible connections: Touch-safe and floodable. Maintenance-free and explosion-proof. Without leakage or environmental risks. With any common screen treating. Buriable version tested for underground use (illustration below on the right). Offshore-certified by the classification society DNV GL.

As a result, the CONNEX epoxy resin joint is ideally suitable

- For the formation, extension and repair of cable runs
- For prefabrication of cable systems that can be installed quickly
- As a voltage-proof terminating element for cable testing
- For use in confined spaces and sensitive environments, e.g. equipment housed indoors, in urban areas, on offshore platforms
- As an easy-to-store reserve for the fastest possible cable repairs

Find out how the CONNEX epoxy resin joint is used as part of the PFISTERER Universal Repair Kit or an offshore system solution in sections 5.2 and 5.3. More product details follow on the next page.

For underground use:

Shrink-wrapped pluggable CONNEX epoxy resin joint, shown here with a view of the inside

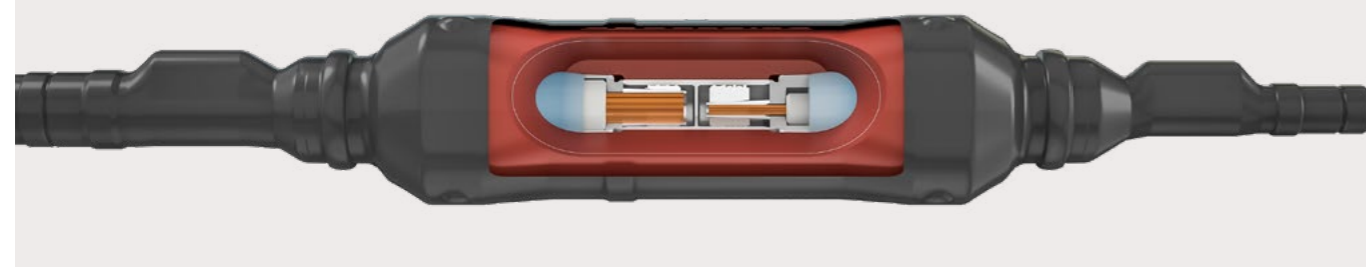

At a glance

- Compact joint for currently up to 170 kV for demanding applications in confined spaces, sensitive environments, underground, offshore:
- Touch-safe joining of two cables of the same or different types
- Fastest possible repair of damaged cable sections
- Assembly of pretested offshore and onshore cable systems
- Easy to use thanks to plug-in connection technology and very high degree of pre-assembly
- Fully dry insulated with epoxy resin
- No handling of liquid or gaseous insulating materials during installation
- No leakage or environmental risks, maintenance-free and explosion-proof
- Floodable, resistant to UV radiation and salty atmospheres
- Offshore-certified by the international classification society DNV GL
- Optional accessories: CONNEX dummy plugs (see section 2.2)
- Available for all common screen versions
- Routine tested before delivery

CONNEX pluggable epoxy resin joints

Size	Highest voltage U_m [kV]	Installation site	Nominal current ¹ I_n [A]	AC withstand voltage 1 min [kV]	BIL* [kV]	Article no.
4	72.5	Outdoor or indoor, offshore	2500	140	325	827 234 001
6	170	Outdoor or indoor, offshore	2500	218	750	827 234 006
6	170	Underground for burial	2500	218	750	827 234 007

* Lightning impulse (withstand voltage)



2.1 Tools for CONNEX components

Assembly, earthing and protective cap

The assembly cap allows the CONNEX cable connector to be pretensioned and heat-shrunk. It is then fully pre-assembled ready for final installation. This is done by plugging it into various CONNEX components: joints, outdoor cable terminations or also sockets on GIS or transformers (details in catalog part 1). The assembly cap also serves as an earthing and protective cap.

At a glance

- Three functions in one tool: Installation, earthing and protection
- Pre-assembly can be carried out anytime, at any suitable location
- For protection against damage as well as ingress of liquids and solids
- Suitable for offshore use

Assembly cap

Size	Article no.
4	827 174 104
6 / 6-S	827 174 106
7 / 7-S	827 174 107



Protective cap

Protects unplugged CONNEX cable connectors that are already fitted on the connection cable or test cable, also pluggable CONNEX bushings and surge arresters, for example from rain when used outdoors.

At a glance

- For protection against damage as well as ingress of liquids and solids
- Use recommended during storage and transportation
- Included with CONNEX bushings and pre-assembled HV cables (with standard order)
- Not voltage-proof

Protective cap

Size	Article no.
4	827 708 011
5-S	827 708 012
6 / 6-S	827 708 013
7 / 7-S	827 708 014
8 / 9	827 708 015



2.1

Solid-insulated dummy plug

For sealing and voltage-proof closing of plug connection points on various CONNEX components: on all solid and gas-insulated joints as well as pluggable outdoor cable terminations for voltage-proof closure when testing the product. Also for sockets installed on transformers and gas-insulated switchgear. Suitable for continuous operation, voltage tests and offshore use.

Solid-insulated dummy plug

Size	Highest voltage U_m [kV]	Article no.
4	72.5	827 700 004
5-S	145	827 701 002
6	170	827 706 013
6-S	245	827 706 014
7	300	827 706 005
7-S	362	827 706 006



Cover disk

Protects unused CONNEX sockets on gas-insulated joints and epoxy resin joints as well as on transformers and GIS against damage and ingress of liquids and solids, for example rainwater when used outdoors.

At a glance

- For protection against damage as well as ingress of liquids and solids
- Suitable for offshore use
- Included with CONNEX joints and cable connectors (with standard order)
- Not voltage-proof



2.2 Tools for gas-insulated CONNEX joints

For the faultless functioning of a CONNEX cable connector in normal operation and its protection in the event of a short-circuit, it is essential that it is installed and used properly.

The following modular CONNEX tools facilitate and support the use of CONNEX cable connectors on all three types of gas-insulated CONNEX joints.

When using CONNEX cable connectors on gas-insulated CONNEX joints, it is important that the cable is properly guided and fixed centrally with the connection point on the joint, as illustrated below. Otherwise, electrical contact between the conductive elements of the plug connector and joint may be impaired, as well as their insulation. In addition, the cable must be secured at its connection point in the event of a short-circuit.

The extra parts and sets are explained in detail below. Together, they provide essential functions for safety and user-friendliness in daily use:

- Precise hold for connected cable ends with CONNEX cable connector
- Stable support and safe movement of CONNEX joints



Cable support and cable clamp set ensure and secure the centric cable position (arrow) on a gas-insulated CONNEX connection joint

The following tools can be used individually or in combination:

Fastening brackets

Serve as basic tools for various safety and handling purposes:

- For fastening gas-insulated CONNEX joints to the ground with bolts
- For attaching the following additional tools to gas-insulated CONNEX joints:



Cable supports with cable clamp set (clamp data in the following table)

Are key elements for safe operation:

- For guiding and fixing the cable centrally with the connection point on the joint for long-term reliable functioning during normal operation and testing
- At the same time, the cable is fastened with the required first clamp to safely absorb transverse forces occurring at this point in the event of a short-circuit
- Cable supports are available for both sides of CONNEX connection joints and T-joints

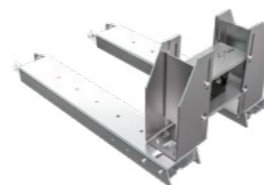

Cable diameter range Ø [mm]	50 - 75	75 - 100	100 - 130	130 - 160	160 - 200
Article no.	562 438 001	562 438 003	562 438 002	562 438 004	562 438 005

Transport casters make joints mobile:

- For easy and safe movement of gas-insulated CONNEX joints
- Ideal for use in test laboratories
- The joint must not be rolled/moved with cables plugged in



Transport sets combine safety and mobility:

- For moving CONNEX joints with cable support fitted
- The joint must not be rolled/moved with cables plugged in



2.2

The composition, method of ordering and packaging units for these accessories vary depending on the type and specified application of gas-insulated CONNEX joints.

The following tables and the footnotes at the end of the page describe general characteristics and special features of specific joints.



CONNEX connection joint



CONNEX elbow joint



CONNEX T-joint

The joints shown here have all the accessories fitted on the right-hand side of the joint. In general, all connection points to which cables are connected should be equipped with suitable cable supports; order-specific requirements for the cable support should be confirmed at the time of ordering.

Tools for gas-insulated CONNEX connection joint

Size	Connection joint Article no.	Fastening brackets Article no. (1 fastening bracket) ¹	Cable support Article no. (1 set) ²	Transport casters Article no. (1 caster) ¹	Transport set Article no. (2 casters + 2 struts)
4	827 049 101	564 940 004	564 943 003	560 091 002	564 943 007
5-S	827 052 101	564 940 004	564 943 003	560 091 002	564 943 007
6	827 053 101	564 940 004	564 943 003	560 091 002	564 943 007
6-S	827 059 101	564 940 004	564 943 003	560 091 002	564 943 008
7 / 7-S	827 078 011	564 940 004	564 943 003	560 091 002	564 943 008
8	827 076 021	564 940 003	564 943 002	560 091 002	564 943 009
9	827 076 031	564 940 003	564 943 002	560 091 002	564 943 009

Tools for gas-insulated CONNEX elbow joint

Size	Elbow joint	Fastening brackets	Cable support (1 set) ²	Transport casters (1 caster) ¹	Transport set (2 casters + 2 struts)
5-S	827 077 010	Already fitted	564 943 004	560 091 001	564 943 005
6	827 077 002	Already fitted	564 943 004	560 091 001	564 943 005
6-S	827 077 003	Already fitted	564 943 004	560 091 001	564 943 005

Tools for gas-insulated CONNEX T-joint

Size	Branch joint	Fastening brackets (1 fastening bracket) ^{3,4}	Cable support 2-way (1 set) ²	Cable support 1-way (1 set) ²	Transport casters (1 caster) ^{1,5}	Transport set 1-way side (2 casters + 2 struts)
4	827 062 101	564 940 002 564 940 003	564 943 006	564 943 002	560 091 002	564 943 009
5-S	827 047 201	564 940 002 564 940 003	564 943 006	564 943 002	560 091 002	564 943 009
6	827 057 101	564 940 002 564 940 003	564 943 006	564 943 002	560 091 002	564 943 009
6-S	827 063 101	564 940 002 564 940 003	564 943 006	564 943 002	560 091 002	On request

¹ Each to be ordered individually; four fastening brackets / four casters required per joint

² Cable clamp set to be ordered separately because its specification depends on the respective cable diameter

³ Each to be ordered individually; joint requires two different fastening brackets, two on each side of the joint

⁴ Fastening bracket -002 for side of joint with two connection points, -003 for side with only one connection point

⁵ For the transport set, only two transport casters are required on the side of the joint with two connection points, as struts are already provided with the cable support

3.1 Basic systems: Terminations on cables

3.1

Efficient quick-deploy systems by PFISTERER are fast, safe and flexible in use. With high-performance components and complementary tools available in different configuration levels to suit your needs. Customized to fit your specified applications and areas of use.

First configuration level: Expandable basic systems consisting of terminations on cables

Practical for testing and construction uses, for example:

- Can be connected to similar or different types of equipment, depending on specification
- Available with different cable lengths and practical tools (see section 2)
- Routine tested as a system before delivery. Corrosion-resistant and maintenance-free.



Can be pre-assembled from versatile basic components:

Dry PFISTERER terminations

PFISTERER offers a large portfolio of solid-insulated terminations (complete in catalog part 2):

- CONNEX cable connector (pictured below) for maximum flexibility in terms of interchangeability and multiple use: Can be plugged into transformers and GIS with suitable CONNEX sockets, and also into the new CONNEX outdoor cable terminations (details in section 1.5). Can also be connected to all CONNEX joints as with the plus systems in the next section. Separable and swappable in each of these use cases.
- Terminations with slip-on technology and application-specific designs: Flexible ESF without support (shown below), EST-SUB with its own support element, EST-SUB SA with integrated surge arrester for equipment protection and support.
- Initial installation and use, remodeling and dismantling of all dry PFISTERER terminations without laborious handling of liquid or gaseous insulating materials, without environmental or leakage risks

Highly flexible rubber cable

- Proven under extreme conditions as are usual in offshore applications
- Robust and extremely flexible

Optional: Cable drum

- For easy transportation, optimal storage, fast deployment
- Suitable for standard containers of different sizes
- With guide rail for transport by forklift
- Optionally with pneumatic drive for rolling cable onto the drum easily and orderly

Examples of basic systems



CONNEX cable connector



CONNEX cable connector



CONNEX cable connector

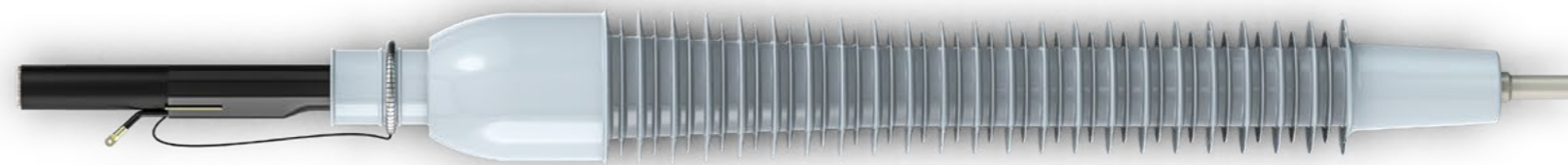

ESF outdoor cable termination

3.2 Plus systems: Extensions with joints

The basic systems from the previous section can be extended and continued as required. For (their) flexible expansion, numerous CONNEX joints are available. Lifelong versatile and easy to install thanks to plug-in technology.

Second configuration level: System extensions with pluggable CONNEX joints

For various applications and usage scenarios on land and at sea:

- For flexible creation, extension or diversion of cable routes
For example as bypasses for equipment bridging as described in catalog part 2
- As voltage-proof terminations or elements of system solutions for testing
Very lean design possible with CONNEX epoxy resin joints, also for confined spaces
- As a mobile solution for the transition from overhead lines and busbars to cables
For example for repairs or revisions, applications in section 4.1

Can be implemented with diverse CONNEX joint types using installation-friendly plug-in technology

Regardless of the insulation type, CONNEX cable connectors of the same or compatible size can be plugged into all CONNEX joints, separated and swapped at any time. Without laborious handling of insulating materials during initial and subsequent installations for temporary or permanent use.

Dry insulated CONNEX epoxy resin joints for up to 170 kV

- Touch-safe jointing of two cables of the same or different types
- For applications in sensitive environments, underground, offshore, etc.
- All production information in section 1.4

CONNEX joints with CONNEX cable connectors

Top: Gas-insulated T-joint
Middle: Gas-insulated connection joint
Bottom: Solid-insulated epoxy resin joint

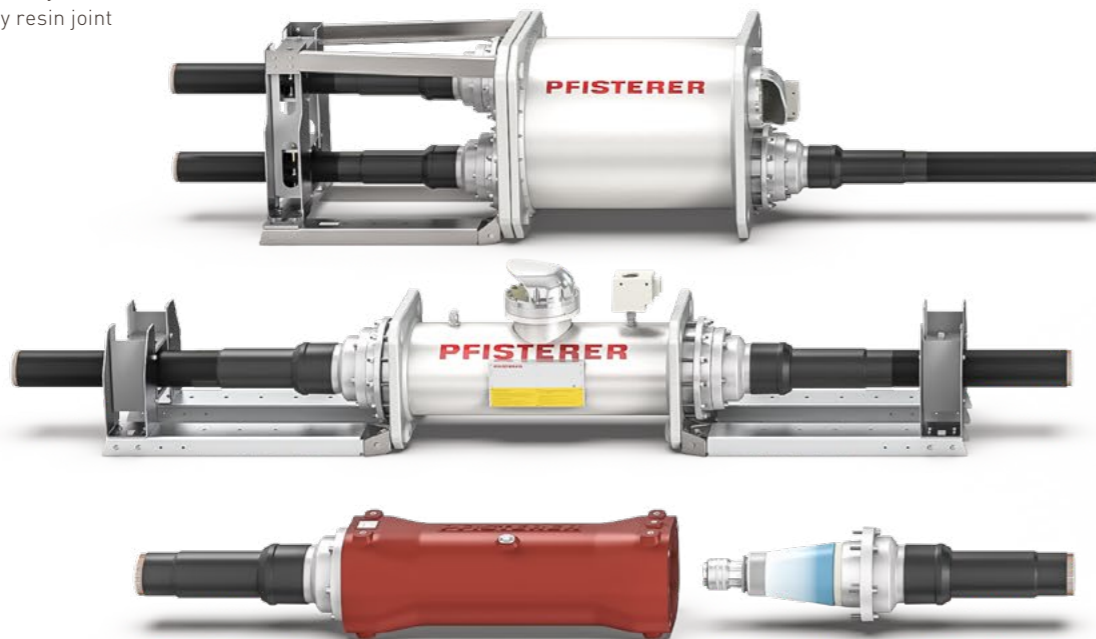

3.2

CONNEX joints for 72.5 to 245 kV or 550 kV, insulated with conventional or alternative gases

- Three construction forms for different jointings: straight, right-angled, branch
- Different cable types can be connected with one joint
- With practical tools for professionally safe use of CONNEX cable connectors on gas-insulated CONNEX joints (in section 2.3)
- All production information in section 1.2



Top: Solid-insulated EST-SUB SA termination with integrated surge arrester
Bottom right: Gas-insulated CONNEX elbow joint
Bottom left: CONNEX cable connection

3.3 Advanced systems: Complete solutions

PFISTERER realizes sophisticated complete solutions for extensive applications and complex requirements from the drawing board to deployment for efficient transportation and use. Including complementary tools and consumables. With installation and usage training.

Third configuration level: Comprehensive PFISTERER system solutions

These implement the quick-deploy approach in an exemplary manner, even for complex requirements:

- **Universal Repair Kit for the fastest possible repair of high voltage cable routes**
Flexible in use on all specified cable types, can be applied long-term as a permanent solution. See how in section 4.2.
- **Universal Routing Kit for immediate deployment for testing and construction uses in a grid area**
Flexible to use on all specified connection configurations on diverse transformers and GIS. Realizes temporary equipment connections, if required with voltage-proof termination.
- **Versatile connecting and jointing systems for mobile transformers and GIS**
Lean, fast and safe in use. Can be flexibly connected to cables and bare conductors. An application example with modular emergency transformers is shown in catalog part 1.
- **Complete solutions for all connecting and jointing interfaces of mobile substations**
During construction work, mobile substations equipped with PFISTERER cable system solutions can be a cost-efficient alternative to months-long outages of vital power grid sections or equally time-consuming installations of replacement solutions, such as temporary overhead lines.



Equipped for many cases and locations. With quality in variety from a single source.

Energy for modern life and business is time when electricity flows smoothly.

With PFISTERER accessories for high voltages you gain power of impact in time-sensitive situations and scope for contemporary development of your power grid infrastructure on land and at sea.

See how in the following outlooks on classic and more recent applications in worldwide operational practice with PFISTERER solutions from all three accessories catalog parts.

Individually, in combination or as modular systems, they form strong supports for power supply grids in line with economic and ecological requirements.

They are **efficient, safe and reliable to use:**
For short-term repairs and emergency interventions. For medium-term **revisions** and cleaning.
For long-term projects such as power grid construction, retrofitting and modernization.

Now discover some of the many ways in which you can sustainably advance your work for security of supply with PFISTERER.



4.1 Versatile components. Variable cable systems. With customized flexibility. For lasting efficiency.

Equip high-voltage grids pragmatically and develop them progressively – with PFISTERER accessories both are achieved safely and economically. The portfolio comprises proven technologies and the largest selection of plug-in technology solutions for lifelong efficiency in reliable use at sensitive grid interfaces. Below is an excerpt from the many options to implement these flexibly as required, starting with transitions between bare conductors as well as XLPE and EPR cables.

Connecting and jointing components between overhead lines, busbars and cable systems do not always serve as permanent interfaces for the transmission of electricity in substations or cable transition stations. In operational practice, there are also many temporary application scenarios ranging from a few hours to several days and also longer periods for various types of work on high voltage and extra high voltage grids.

Sections of overhead lines are bridged in order to carry out planned remodeling or extensions of transmission grids, or necessary repairs after storm damage. In substations, interim solutions are required when maintaining or renewing equipment. Likewise for voltage tapping for testing new cable routes or existing transformers after cleaning, for example. And many more situations.

Crucial for efficiency

As different as the reasons, requirements and durations may be for the use of interface solutions between conductors of different or the same types, in all cases the same properties are crucial for their efficient design and lifelong use:

The connecting and jointing accessories can be professionally installed as quickly and easily as possible, without handling liquid or gaseous insulating materials. They are modular and can be used multiple times. If required, they can also be utilized variably on diverse equipment and in different connecting constellations, depending on how many applications are to be covered in one area of activity or grid area. The PFISTERER accessories shown here and on the following pages combine these attributes with specific features for special applications and requirements.

Versatile and lean across levels and around corners

Depicted on the far left is a CONNEX bushing plugged into the CONNEX elbow joint. This highly versatile joint is part of the product series of gas-insulated CONNEX joints for voltages up to currently 245 kV or 550 kV (details in section 1.4). The individual joint types are available with conventional or optional alternative insulating gases.

Besides the gas-insulated joint types for straight connections or branches, the elbow joint shown here enables a wide range of right-angled connections on the same level or across several floors. All common XLPE and EPR cables with CONNEX cable plugs as well as CONNEX bushings for connecting bare conductors can be plugged in. This results in maximum flexibility of use with conductors of the same or different types, which can be connected neatly around corners or across levels on different heights, even in tight spaces.

CONNEX elbow joints can therefore be used in many practical ways: To supply equipment for a short time on cable from a busbar or overhead line (pictured on the far left) or occasionally for an electrical test. As elements of system solutions with cables that can be pre-assembled with diverse PFISTERER terminations using slip-on or plug-in technology, for example with EST-SUB for substations (application in the middle). If permanent connections are required, PFISTERER offers the largest portfolio of terminations on the market. This means that specifications can be created for all scenarios. The self-supporting DOC (third application from the left) can be installed very

quickly thanks to its prefabricated central unit. Retrofit solutions even allow obsolete terminations to be replaced, giving a cable system a new life cycle. (All terminations and system solutions are shown in Part 2 of the catalog).

Maximum flexibility in lifelong use

The CONNEX family with the widest range of components using plug-in technology provides long-term flexibility for connecting equipment and joining cables.

Every cable achieves maximum range of use with CONNEX cable connectors at both ends: Then it can also be plugged simultaneously into all CONNEX joints of the corresponding size or into GIS and transformers with suitable CONNEX sockets. The latter form universal interfaces for variable connection of diverse pluggable CONNEX components: cable connectors, bushings, surge arresters (the CONNEX system concept is explained in catalog part 1). Cable systems with CONNEX master all applications that demand fast assembly and removal as well as robustness against environmental factors. The following underground and offshore applications show how.

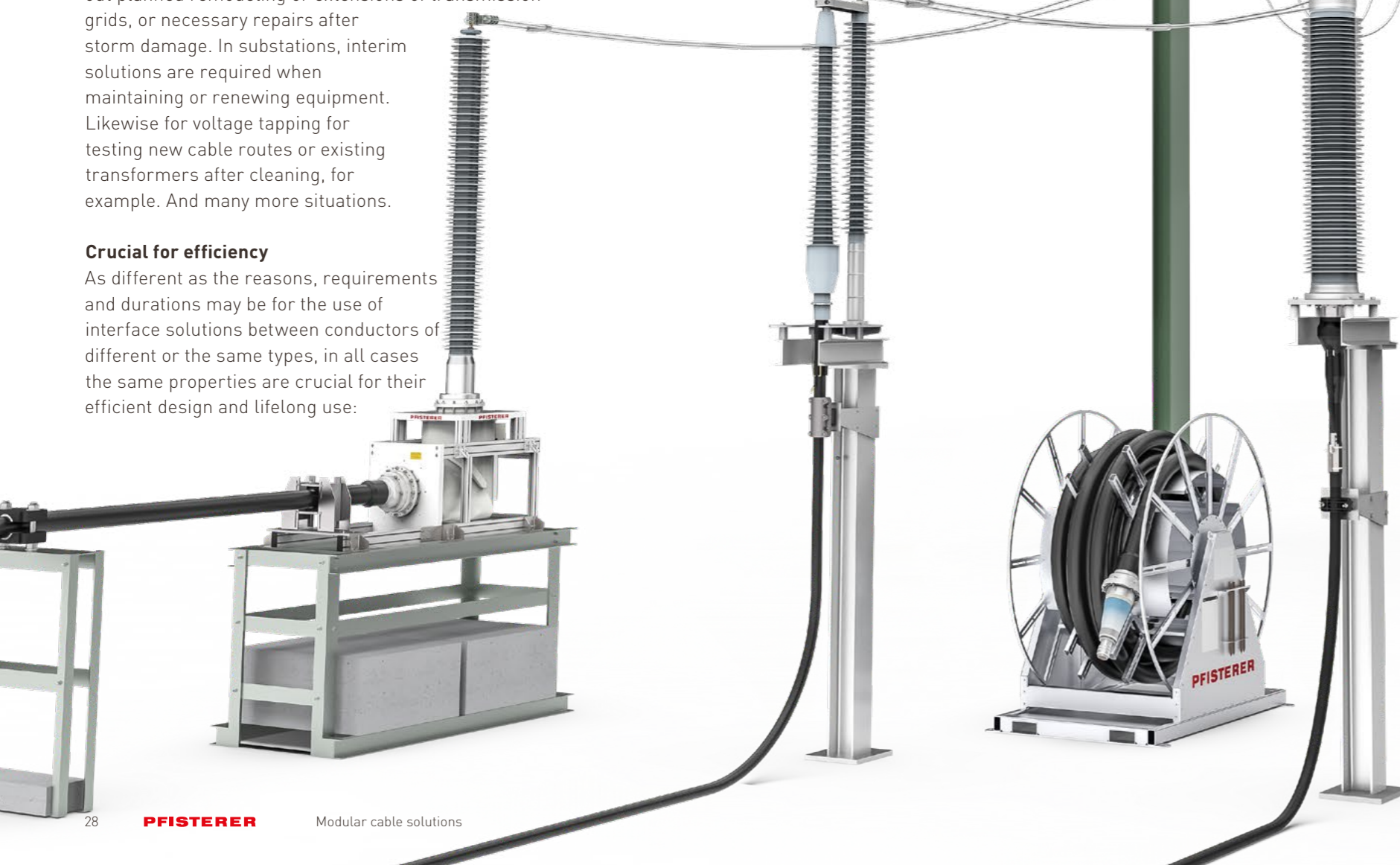

4.2 Real risks managed the lean and secure way. With one repair solution for different cables.

For the fastest possible repair of high voltage cable routes, there is no need for a crystal ball to know when any particular cable might be at risk of damage. Because PFISTERER provides power grid managers with a powerful instrument: The Universal Repair Kit is tailor-made for flexible usability on all defined cable types in a grid area. Lean and long-time storable. Ready to use immediately. Fast to install. Reliable in operation as a permanent solution.

There are many causes for cable route faults: Excavators frequently damage cables during construction work. Weather, water ingress, aging and other factors can severely disrupt their functioning. For grid managers, these and other everyday risks always present the same dilemma between the highest security of supply and the equally needed profitability:

Extended downtimes due to cable faults are now more than ever a real scenario due to often lengthy procurement times for replacement solutions. Alternatively, there is the option of stocking spare parts, which becomes more costly the more different cable types are laid in a power grid.

That's why PFISTERER opens up a better way with the Universal Repair Kit for above-ground and underground cables. It combines versatile cable accessories in precise, application-specific configurations. As a result, the scope of each repair kit is exactly streamlined according to requirements. And its contents completely cover all predefined XLPE and EPR cable types when in use.

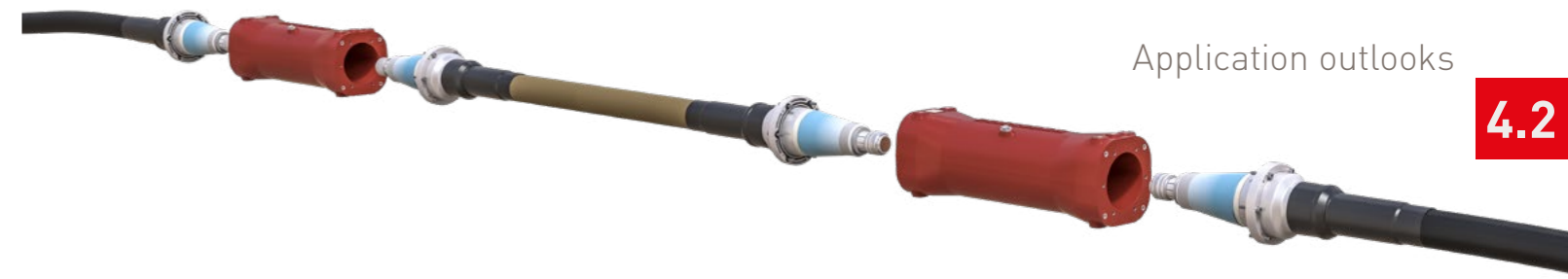

User-friendly for all grid-relevant cables

Two central components of the repair solution are proven indoors and outdoors in long-term operation, and are depicted above in a straight installation arrangement: CONNEX plug connectors serve as connecting parts at the ends of the existing cable and the replacement cable. CONNEX epoxy resin joints act as connecting elements between them.

Both are characterized by their ease of installation thanks to their design features of solid insulation and plug-in technology. The cable connectors are connected to the epoxy resin joints by plug-in-process – without laborious handling of gaseous or liquid insulating materials. The compact design of both CONNEX components additionally supports their integration into cable trenches and shafts.

CONNEX cable connectors and joints can be used in a wide variety of ways: Suitable for all globally widespread XLPE and EPR cables, they connect the same or different cable types, whether rigid or flexible, with aluminum or copper conductors, as well as different diameters and insulating materials (see also product sections 1.1 and 1.4). In addition, all common methods of cross-bonding and treating cable screens are possible with CONNEX epoxy resin joints. Catalog part 2 contains suitable link boxes for each.

No component too many. Everything necessary sorted.

The modular design of CONNEX cable connectors allows the assortment of parts in the repair solution to be precisely focused on the defined application spectrum – with cable-specific components and those that universally fit different cable types.

For professional, fast transportation and use, PFISTERER supplies all necessary components, additional tools and consumables systematically pre-sorted in weatherproof container boxes and clearly coded for easy reordering. An overall plan is included, with an overview of all boxes, their contents and application areas. The correct performance of all work steps is described in the accompanying installation instructions, and is taught in advance by PFISTERER in obligatory training courses (see section 5).

Thus optimally prepared, the repair runs smoothly: Once the defective section of a cable route has been located, exposed and cut out, suitable CONNEX plugs are fitted to the remaining cable ends. Then a replacement cable is positioned in between. This is pre-assembled with CONNEX plug connectors or is then fitted with them when applied. Finally, all the plug connectors are plugged into CONNEX joints, fixed and, if necessary, shrink-wrapped – and that's it. The cable shaft can now be sealed, with the installed repair components remaining inside as a permanent solution for operation.



4.3 Leading the way: With CONNEX long-term high performing on high seas and on land

In the turbulent wind energy business too, CONNEX acts as a strong lever in the field of tension between security of supply, environmental protection, time and cost pressure: The offshore-certified connecting and jointing system has been convincing in maritime use for more than 20 years thanks to its technological edge and potential for the future: Quickly installed. Reliable and maintenance-free in long-term operation. With the greatest variety of components for turnkey systems in ever higher voltages.

The increase from 33 kV to 66 kV in inter-array cabling between wind turbine generators (WTGs) and offshore substations marks a milestone in the recent history of offshore wind energy. The switch from medium to high voltage is driven by the overarching goal of achieving higher power output at lower cost. And the next step up to even higher voltage levels is already on the horizon: New-generation WTGs are becoming even more powerful. 66 kV will not be enough for their inter-connection. So the trend is clearly moving toward 145 kV and beyond.

Certified for offshore. Proven in operation.

As a pioneer and driver of innovation, PFISTERER supports the progress of offshore wind energy with the continuous development of CONNEX. The connecting and jointing system for voltages up to currently 550 kV was the first of its kind to be offshore-certified by DNV GL, the world's largest classification and consulting company for ships and WTGs. For over 20 years, CONNEX has been in versatile use in numerous offshore installations, including pioneering ones.

For example, connecting the inter-array submarine and tower cables of 102 WTGs in East Anglia ONE, the first large-scale wind farm with a 66 kV grid. Another first in the North Sea was realized with CONNEX at the DolWin gamma converter station: the first installation of a highly flexible 155 kV cable with connecting and jointing accessories from the CONNEX range.

Strong lineup for sensitive applications

The advantages of the CONNEX family at component and system level explain its lead in offshore applications today and in future. It comprises touch-safe, floodable, salt and UV-resistant cable plugs, connection joints and T-joints, plus surge arresters and extra tools for pre-assembly, component protection, testing and more. As a result, PFISTERER offers the largest portfolio for turnkey connection systems with advanced solid insulation and plug-in technology. Designed to be friendly for users and the environment, CONNEX solutions ensure constant power flow in WTGs and converter stations as well as offshore and onshore substations in a sustainable and cost-efficient manner.

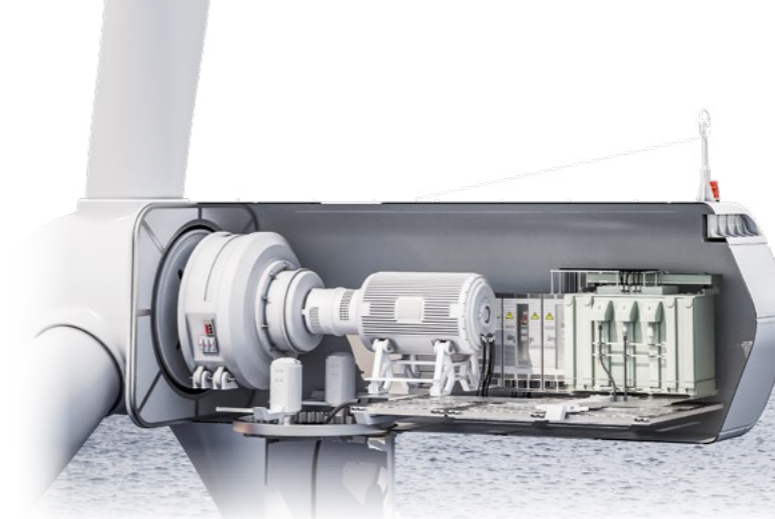

Installation-friendly in all situations. Efficient lifelong.

The CONNEX cable connector (plug) bundles crucial advanced design features. Versatility and full encapsulation coupled with solid insulation, plug-in technology and rotatable bell flange ensure its efficiency in all life-cycle stages: The CONNEX plug can be prefitted and pretested on all common XLPE and EPR cables ready for connection. Its final installation is always carried out by plugging it in, whether into CONNEX joints or GIS and transformers – without intervening in their inner workings, without handling gaseous or liquid insulating materials, and without twisting the cable to connect it.

Once live, the CONNEX cable connector is touch-safe, maintenance-free in operation and extremely robust thanks to the separation of mechanical and electrical contact in its design. The cable connector is screwed at the outside of the flange bell and thus fixed. The electrical contact is made in the protected interior. Insights into the CONNEX connector in catalog part 1 show how tried-and-tested technical principles ensure lifelong reliable functioning.

CONNEX epoxy resin joints for up to 170 kV are also recommended as top team players for offshore solutions. They too are solid-insulated and pluggable, maintenance-free in use, touch-safe and versatile. In compact designs for straight cable routing or branches, they connect cables of the same or different types equipped with CONNEX plug connectors. CONNEX epoxy resin joints and cable connectors therefore form the strong basis of offshore systems up to 170 kV.

As power outputs increase, the dimensions of offshore structures are growing and so is the need for modular designs comprising largely prefabricated components with built-in technical equipment. CONNEX systems accompany this trend: Pretested as a whole. Can be pre-assembled in sections in wind turbine tower segments or platform modules. Efficiently pluggable together on site. With flexible expansion options with CONNEX or other PFISTERER products from a single source.

Dropper cables, for example. In WTGs, they connect the GIS to interface joints with the inter-array cable (on the left in the picture below). PFISTERER makes this connection using highly flexible Class 5 rubber cables with prefitted CONNEX plugs and compatible epoxy resin joints. PFISTERER can extend these systems in any direction: Up into WTG nacelles (pictured above) with PLUG connectors as generator connections. Down to the inter-array cable connection. In addition, CONNEX complete systems are available for substations offshore (pictured below) and onshore. Including device protection, where space-saving design is possible with compact pluggable CONNEX surge arresters.



5.1 Installation know-how for safe initial operation

High voltage places the highest demands on the safety and reliability of systems as well as connecting components and complementary tools. Their quality is not the only deciding factor. Professional installation is equally important – based on practical experience. HV components from PFISTERER are therefore installed exclusively by specialist personnel who have received product-specific training and certification. For the sake of lifelong operational reliability. And also important to maintain the warranty.

To this end, PFISTERER provides comprehensive know-how transfer in practice and theory:

Installation service

PFISTERER supports you worldwide at regional level with installation services. Provided by our own installation teams or partner firms certified according to strict PFISTERER criteria. With experience of working in a variety of conditions. In a cable trench. In a dry dock. On offshore platforms. With expert knowledge and a precise feel for a wide variety of cable technologies and grounding concepts, all the way to connecting fine fiber optic cables to monitoring boxes. In every situation, competent and efficient in tried-and-tested work steps for safe and professional installation.

Installation training

For the qualification of your fitters, PFISTERER arranges the obligatory high voltage installation trainings in the company's own training centers worldwide or also individually on your premises.

All training courses include detailed product training as well as requirements, preparations and carrying out the installation, with practical exercises and tasks. The training content can be adapted to specific training needs, for example the process of plugging in a CONNEX bushing, cable connector installation in confined spaces with the aid of an assembly cap, or the installation of mobile interim solutions.

Upon successful completion of the course, each participant receives a time-limited certificate. This authorizes them to work independently with the product system they were trained in.

The standard training courses, which can be extended, include:

- Safety briefing
- General production and application knowledge
- Overview of installation procedure and installation instructions
- Design and components of the accessory
- Cable preparation
- Assembling the accessory on the cable
- Installing the accessory on the equipment or in the cable route, if necessary with grounding system

Installation instructions

The safe and proper installation for PFISTERER accessories is described in detail with text and illustrations in product-specific installation instructions. They are enclosed with each delivery as part of the product. Each set of instructions must be read in full before starting work, followed step by step, and kept accessible at all times in the immediate vicinity of the product, for example in the control center or switch room.



5.2 Engineering expertise for individual solutions

Efficiently bridge grid equipment, repair cables as quickly as possible, provide mobile power, carry out tests safely, etc. Demanding applications like these and others at high voltage require customized cable system solutions. PFISTERER does the work for you – happy to be your highly capable project partner with:

- **Expertise** in the development, design and realization of individual connecting and jointing systems including installation tools as well as transportation and storage solutions
- **Routine** in diverse interfacing activities between designers, manufacturers and operators of high voltage grids and systems
- **Worldwide project experience** with complex cable system applications, for example highly compact emergency transformers and complete mobile substations for large-scale grid remodelings



This QR code will take you to exemplary projects with customized PFISTERER solutions.

Would you like support with your project?
Email us at info@pfisterer.com.
We are looking forward to your project!

Issue 1-2024

PFISTERER editorial team

Peter Arranz, Vukašin Basara, Andreas Dobler, Alejandro Escobin, Natalie Fischer, Thomas Friedel, Maximilian Kraus, Thorsten Ludwig, Wadim Mirau

Content conception and text editing

Karolina Kos, xyzeiler.de

Art direction and visual design

David Kaiser, DaKa.design

Disclaimer & copyright

The catalog contents have been compiled and checked with care. No liability is assumed for any inaccuracies or errors. We reserve the right to make changes due to updates. All catalog contents are protected by copyright. Copies in whole or in part require the written permission of PFISTERER.

© PFISTERER Holding SE

PFISTERER S.A.

Av. Velez Sarsfield 464
C1282AFR Buenos Aires
Argentina
Phone: +54 9 11 4304 7114
Fax: +54 9 11 4362 2381
www.pfisterer.com.ar

PFISTERER is a globally leading and independent technology company with head offices in Winterbach near Stuttgart, Germany. We develop, produce and sell technology for insulating and connecting electrical conductors for power grid interfaces - from the generation and transmission to the distribution of electrical energy. With state-of-the-art production facilities, high quality standards, and technological expertise, we contribute to a safe and reliable energy supply for the future.