

# Connecting systems for transformers and GIS

High and extra high voltage



**Catalog part 1 / 3**

# WELCOME!

In this first part of the catalog you will find connection solutions from PFISTERER for high and extra high voltage with complementary tools for lifelong high-performance transformers and gas-insulated switchgear (GIS), economical from the time of manufacture and reliable in operation.

The product portfolio consists mainly of the proven versatile CONNEX system with internally dry insulated and pluggable components, from cable connectors and bushings to surge arresters and further tools for testing, earthing and short-circuiting, as well as installation and fastening. This selection is complemented by a bushing specifically for GIS with an insulating-gas reducing effect.

For each product, this catalog gives you detailed information with data and pictures. In addition:

- **Overviews of positive effects and uses** of the CONNEX system for manufacturing and operating GIS and transformers
- **Insights into technologies** that ensure reliable electrical contact and insulation as well as efficient, professional installation
- **Outlooks on possible applications** of PFISTERER components based on various equipment configurations and usage constellations, stationary as well as mobile
- **Information on services accompanying products:** Installation service and training, as well as engineering

#### Would you like more information?

Send your request by email or give us a call:

**Contact details are on the last outer page.**

PFISTERER specialists for interface solutions will be happy to answer your questions.

**In the meantime PFISTERER wishes you an informing and inspiring read!**

More advanced PFISTERER interface solutions for your high and extra high voltage applications appear in:

**Catalog part 2 with the entire PFISTERER portfolio of modern and conventional terminations, as well as connection joints and link boxes.**

They can be custom-fit combined and configured for numerous interface applications from overhead lines, in cable routes and in substations.

**Catalog part 3 with more CONNEX components using advantageous plug-in technology such as joints, optional tools and pre-assembled cable solutions,** combinable and configurable on a custom basis for special permanent and temporary applications as a bypass, offshore, for revisions, remodelings, etc.

# Contents

<b>1</b>	<b>Introduction to the CONNEX system</b>	Page 06 - 09
	1.1 Strong components for strong equipment.....	06
	1.2 Connect and protect with the CONNEX system .....	08
<b>2</b>	<b>Components for transformers and GIS</b>	Page 10 - 25
	2.1 CONNEX socket.....	12
	2.2 CONNEX pluggable cable connector.....	14
	2.3 CONNEX pluggable surge arrester.....	16
	2.4 CONNEX pluggable bushing.....	18
	2.5 Gas-insulated bushings for GIS.....	20
	2.6 CONNEX complements.....	22
<b>3</b>	<b>Technology insights</b>	Page 26 - 33
	3.1 CONNEX pluggable cable connector.....	28
	3.2 CONNEX with FrontCon technology for complex conductors.....	32
<b>4</b>	<b>Application outlooks</b>	Page 34 - 41
	4.1 Safe, secure and compact equipment for sensitive areas .....	36
	4.2 Variable devices for efficiency in operation and testing.....	38
	4.3 Modular units for flexible and mobile use .....	40
<b>5</b>	<b>Services</b>	Page 42 - 43
	5.1 Installation: service, training, instruction.....	42
	5.2 Engineering .....	43



Socket



Pluggable cable connector



Pluggable surge arrester



Pluggable bushing



Gas-insulated bushings



Pluggable dummy plug



Earthing and short-circuiting device



Blind cover



Cable support system for cable connectors



Assembly cap for cable connectors

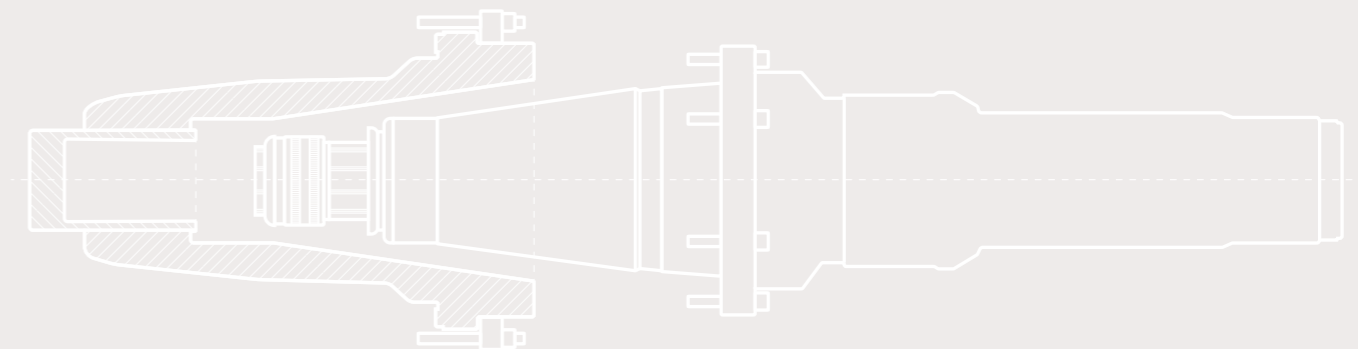

This product catalog contains a representative selection of the most prevalent products from the PFISTERER range. Additional versions and custom applications can be available on request. Products described as optional complementary tools are not included in the standard scope of supply and have to be ordered separately if required.

# 1.1 Strong components for strong equipment. Benefits for grids with PFISTERER solutions.

connecting components and extra tools for transformers and gas-insulated switchgear (GIS) have a decisive influence on how safely and economically equipment is designed and operated throughout its service life. We see this from worldwide practice in its planning, manufacture and operation. That is why PFISTERER combines advanced technologies with a variety of components in a modular system for efficient grid connection and equipment protection.

With pluggable CONNEX solutions for transformers and GIS, you can:

**Set standards for cost-efficient and environmentally friendly equipment designs**

With fast-to-install, anytime replaceable and maintenance-free components for grid connection and surge protection. For example with CONNEX cable connectors thanks to their space-saving and dry-insulated design.

**Optimally designed for demanding operating conditions**

Compact and enclosed for tight spaces in the city, on offshore platforms, in caverns. Resistant to dust, dirt, moisture, salty atmospheres, UV radiation, cold and heat.

**Safe and secure for trouble-free initial operation**

Transformers and GIS are factory tested, easy to transport and can be delivered ready to connect, all in a closed condition.

With user-friendly connection technology that minimizes the risk of installation errors.

**Reliable in operation for decades**

Thanks to proven technologies, type-tested designs, individually tested quality. With solutions for increased safety requirements: Compact arresters for optimized surge protection directly on the transformer and GIS. Components suitable for offshore, certified by the international classification society DNV GL.

**Simplify routines and plan for the future**

Cable connections can be made touch-safe, thus reducing risks and workload for maintenance personnel. Not only can current and voltage tests be carried out without extensive interventions in the transformer and GIS, but also new configurations can be realized over the course of their operating life, for example: changing from an overhead line connection to a cable connection or vice versa; variable star point treatments for various protective measures on the transformer.

**Modernize existing equipment economically**

CONNEX can be retrofitted at any time, with the same positive effects as when used on new equipment.

**With CONNEX, you rationalize operation, protect existing installations and make the use of GIS and transformers more flexible.**

The next two pages show how CONNEX works as a modular system with a universal interface for many pluggable components.



# 1.2 Connect and protect with the CONNEX system: One interface for pluggable components

The centerpiece of the CONNEX system is the dry with solids insulated. It is installed in GIS and transformers, in the terminal boxes or also directly on the casing of transformers, as a fixed and at the same time versatile interface for numerous pluggable CONNEX connection and complementary components.

### Absolute integrity of transformers and GIS with maximum usage flexibility

All CONNEX components of a size defined by voltage range can be connected to a CONNEX socket of the same or compatible accessories size: cable connector or bushing, also surge arrester or earthing and short-circuiting tool. Using plug-in technology, the fastest and safest installation technology not only for cable accessories, but also for bushings.

The CONNEX component is inserted into the socket and then fixed in place. Once plugged in, it remains flexible in many ways: the component can be unplugged at any time and replaced with a similar or different CONNEX component of the same size – without interventions in the terminal box or housing and inner workings of the equipment.

CONNEX is flexible and proven in use with all common insulation media for transformers and GIS: from classic mineral oils and gases, to alternative media such as esters or eco-efficient gases.

### With positive effects for manufacturing and operating high voltage equipment

- Electrical equipment in sealed condition during factory testing and delivery, as well as during installation and commissioning test
- Minimized installation and maintenance costs without gas and oil work on components or equipment
- Space-saving connection configurations and transformer designs for tight operating spaces in buildings
- Equipment can be flexibly repurposed, as it can be variably connected to cables and overhead lines without interventions
- Surge protection can be optimally placed directly on transformers or GIS in a lean way
- Transformer star points can be used flexibly for various protective measures: grounding, insulation, ground fault compensation

### Safe and reliable

- CONNEX solutions for high and extra high voltage are type-tested and individually tested based on various requirements of international standards (IEC, IEEE, etc.)
- Plug-in installation on a closed unit, so without risky interventions in its internal workings or components
- Therefore no risk of leakage and minimized risks for the environment
- Touch-safe, floodable and maintenance-free cable connections can be implemented with CONNEX
- Cable connections, joints and surge arresters certified for offshore applications are available

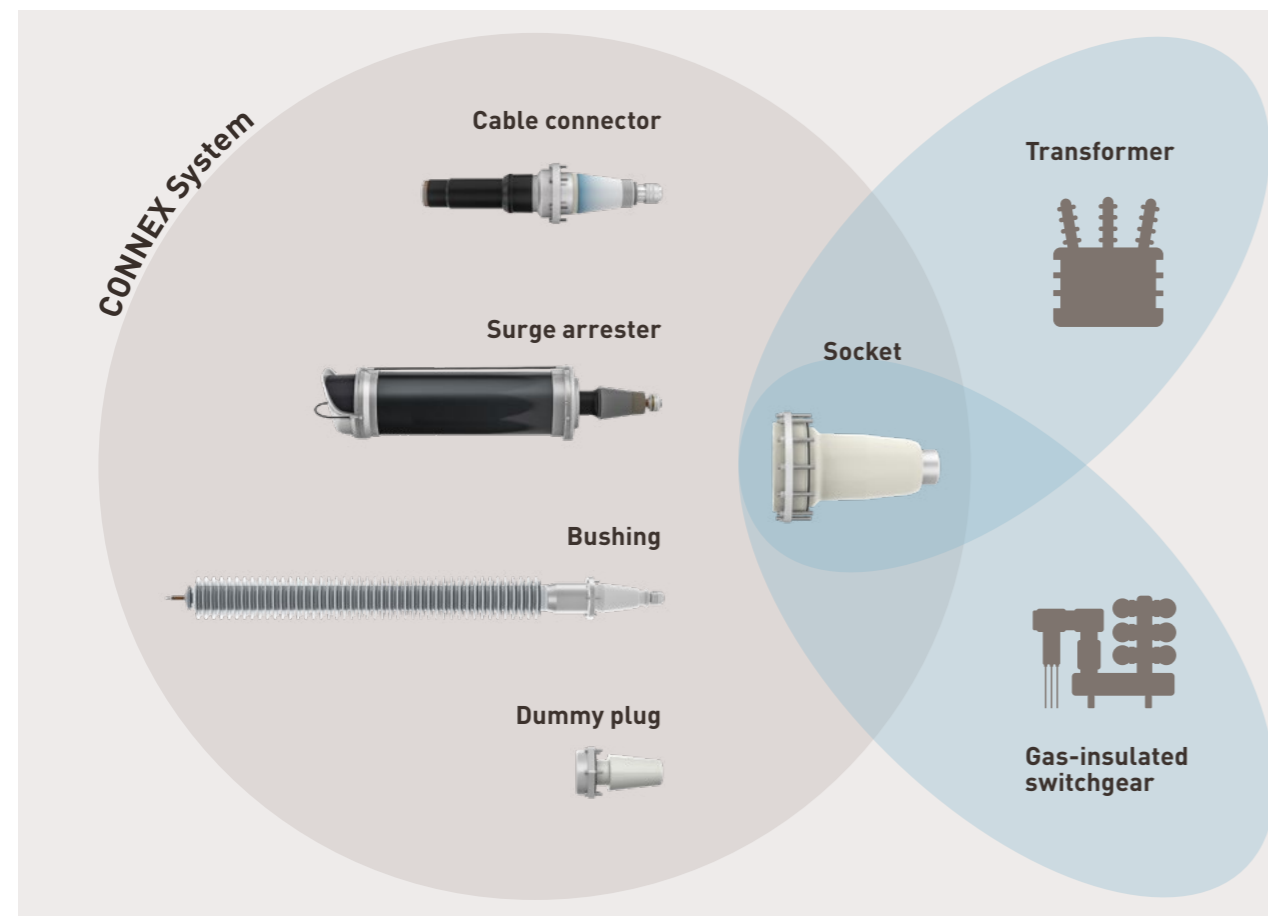



## Solutions for transformers and GIS. Tested quality from PFISTERER.

The following pages provide you with detailed information on the individual connecting components and extra tools from 72.5 kV to 550 kV for transformers and gas-insulated switchgear.

**PFISTERER solutions represent technical progress based on proven technologies and tested designs.**

Designed with know-how gained from 100 years of experience in the transmission of high currents and insulation of high voltages.

**Developed, manufactured and assembled to the highest quality standards using state-of-the-art processes at PFISTERER sites in Europe,** certified to ISO standards for quality and environmental management as well as occupational health and safety, and also qualified under various well-known industry standards and special requirements of many customers from around the world.

Solutions from PFISTERER for high and extra high voltage are type-tested and individually tested based on various requirements of international standards (IEC, IEEE, etc.). Testing is carried out at PFISTERER high voltage lab and in end-of-line test fields, or at recognized external test institutes.

**PFISTERER accessories also successfully complete system tests with various HV and EHV cables according to demanding customer specifications** that exceed standard requirements. In addition, they prove their performance capability in prequalification tests lasting several months, which simulate decades of operation under real operating conditions. These additional tests are performed in cooperation with users and cable manufacturers, either internally or externally, in the laboratory or in the field, depending on testing requirements.

# 2.1 CONNEX socket



## For transformers

The CONNEX socket forms the device-side built-in interface between the transformer and other pluggable CONNEX components. The socket can be installed in any position. The appropriate connection geometry is guaranteed by compliance with all current standards. Advantages result from the possibility to carry out the installation on the transformer in the factory. This enables complete factory testing of the transformer. Only the plugging-in procedure is carried out during the connection installation on site, which greatly reduces the installation time.

### At a glance

- More compact design than possible according to standard
- No restrictions with regard to installation positions
- Connection geometries and installation lengths in accordance with **EN 50299-1** and **EN 50299-2**
- Routine tested before delivery



### CONNEX Socket – Transformer

Size	Highest voltage $U_m$ [kV]	Nominal voltage $U_n$ [kV]	Conductor to ground voltage $U_0$ [kV]	BIL* [kV]	Nominal current $I_n$ [A]	Installation length <sup>1</sup> $l_5$ [mm]			Article no. (variants)
						Compact design	EN 50299-2	EN 50299-1	
4	72.5	60 - 69	36	325	2500	-	310	583	828 041 999 XXXXX
5-S	145	132 - 138	76	650	2500	410	470	757	828 051 999 XXXXX
6	145	132 - 138	76	650	2500	410	470	757	828 061 999 XXXXX
6	170	150 - 161	87	750	2500	410	470	757	828 061 999 XXXXX
6-S	245	220 - 230	127	1050	2500	470	620	960	828 066 999 XXXXX
7	300	275 - 287	160	1050	4000	470	620	960	828 071 999 XXXXX
7-S	362	330 - 345	190	1175	4000	505	960	1400	828 071 999 XXXXX
8	420	380 - 400	220	1425	4000	750	960	1400	828 081 999 XXXXX
9	550	500	290	1675	4000	750	960	1400	828 081 999 XXXXX

1) Values are based on the use of mineral oil as insulating medium. Installation lengths may differ when using ester.

\* Lightning impulse (withstand voltage)

### Extension adapter

For adapting the length of the socket to relevant standardized lengths

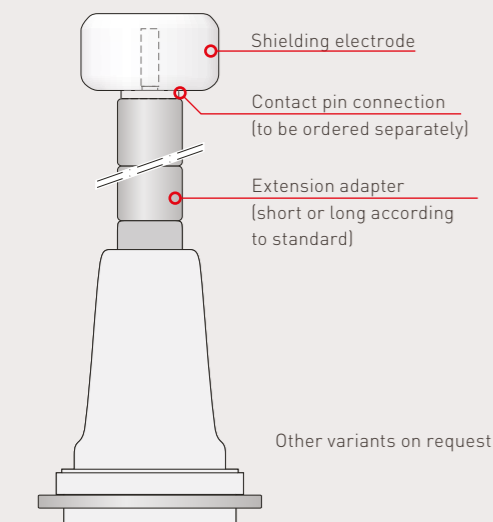

### Voltage tap and venting valve

All sockets have a grounded voltage tap. This can be used for connection to a voltage indication system. When installed vertically from above, a venting valve is integrated into the flange to prevent trapped air.

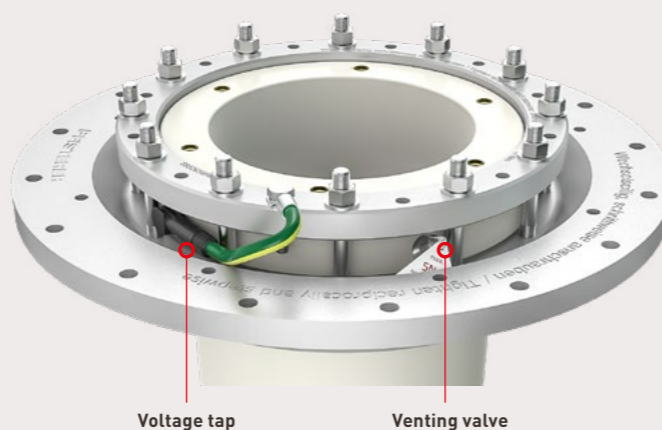

### CONNEX Socket – GIS

Size	Highest voltage $U_m$ [kV]	Nominal voltage $U_n$ [kV]	Conductor to ground voltage $U_0$ [kV]	BIL* [kV]	Nominal current $I_n$ [A]	Installation length $l_5$ [mm]			Article no. (variants)
						Compact design	IEC 62271-209 Fig. 5	IEC 62271-209 Fig. 3	
4	72.5	60 - 69	36	325	2500	-	310	583	828 040 999 XXXXX
5-S	145	132 - 138	76	650	2500	410	470	757	828 050 999 XXXXX
6	145	132 - 138	76	650	2500	410	470	757	828 060 999 XXXXX
6	170	150 - 161	87	750	2500	410	470	757	828 060 999 XXXXX
6-S	245	220 - 230	127	1050	2500	410	620	960	828 065 999 XXXXX
7	300	275 - 287	160	1050	4000	505	620	960	828 070 999 XXXXX
7-S	362	330 - 345	190	1175	4000	505	960	1400	828 070 999 XXXXX
8	420	380 - 400	220	1425	4000	750	960	1400	828 080 999 XXXXX
9	550	500	290	1550	4000	750	960	1400	828 080 999 XXXXX

\* Lightning impulse (withstand voltage)

## For gas-insulated switchgear (GIS)

The CONNEX socket forms the device-side built-in interface between the GIS and other pluggable CONNEX components. The socket can be installed in any position. The appropriate connection geometry is guaranteed by compliance with all current standards. Advantages result from the possibility to carry out the installation on the GIS in the factory. This enables complete factory testing of the GIS. Only the plugging-in procedure is carried out during the connection installation on site, which greatly reduces the installation time.

### At a glance

- More compact design than possible according to standard
- No restrictions with regard to installation positions
- Connection geometries and installation lengths in accordance with **IEC 62271-209**
- Routine tested before delivery



### Extension adapter

For adapting the length of the socket to relevant standardized lengths

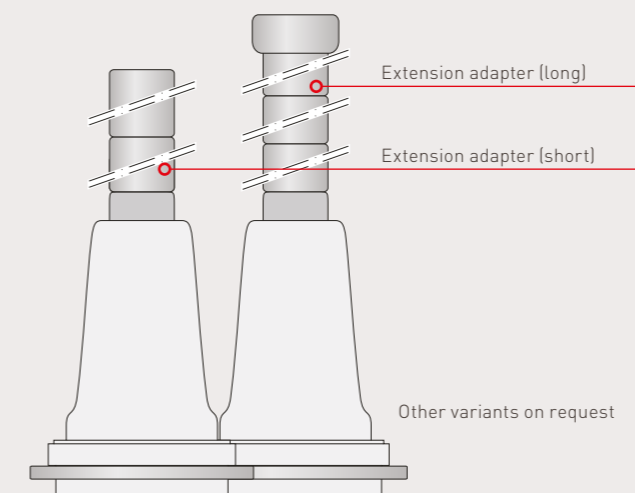

All variants conforming to standard and in compact design can be found in the PFISTERER online catalog.

#### Transformer variants

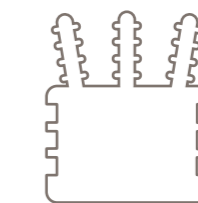

#### GIS variants

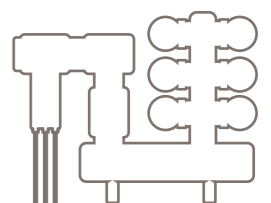

## 2.2 CONNEX pluggable cable connector



The CONNEX cable connector is variably configurable so it can be used for any XLPE and EPR cable. The advanced contact system technology offers mechanical and electrical reliability as well as a high degree of flexibility: After it has been prefitted to the cable, the connector simply plugs into the CONNEX socket – which is permanently mounted on transformers and GIS – to complete the installation. The cable connector is separable at any time and can be plugged into other equipment or components with a suitable CONNEX interface, such as various CONNEX joints or the CONNEX outdoor cable termination (for both product groups see catalog part 3). The cable connection is offshore certified and suitable for low temperature (optional).



### At a glance

- Considerably reduced installation time thanks to plug-in technology
- Horizontal, vertical and inclined arrangement possible, compact connector design
- Connector is separable and can be swapped at any time
- Touch-safe, floodable and maintenance free
- Oil and gas free as fully dry-insulated, no leakage or environmental risks
- Routine tested before delivery

### CONNEX pluggable cable connector

Size	Highest voltage $U_m$ [kV]	Nominal voltage $U_n$ [kV]	Conductor to ground voltage $U_0$ [kV]	Nominal current $I_n$ [A]	Conductor cross-	Conductor	Diameter over	Article no. <sup>4</sup> (variants)
					section <sup>2,3</sup> [mm <sup>2</sup> ]	diameter <sup>3</sup> [mm]		
					RM	RM		
4	72.5	60 - 69	36	2500	95 - 2000	9.3 - 55.9	33.0 - 78.5	849 999 999 XXXX
5-S	145	132 - 138	76	2500	95 - 2000	9.3 - 55.9	36.5 - 76.0	859 999 999 XXXX
6	145	132 - 138	76	2500	95 - 2500	9.3 - 65.0	36.0 - 113.5	866 999 999 XXXX
6	170	150 - 161	87	2500	95 - 2500	9.3 - 65.0	36.0 - 113.5	866 999 999 XXXX
6-S	245	220 - 230	127	2500	95 - 2500	9.3 - 65.0	36.0 - 113.5	866 999 999 XXXX
7	300	275 - 287	160	4000	500 - 3000	24.8 - 72.5	75.0 - 131.0	877 999 999 XXXX
7-S	362	330 - 345	190	4000	500 - 3000	24.8 - 72.5	75.0 - 131.0	877 999 999 XXXX
8	420	380 - 400	220	4000	500 - 3000	24.8 - 72.5	65.0 - 144.0	889 999 999 XXXX
9	550	500	290	4000	500 - 3000	24.8 - 72.5	65.0 - 144.0	899 999 999 XXXX

- $I_n$  for cable accessories (depending on cable cross-section)
- The cross-section range is an indicative value only. The range can only be achieved if the min./max. diameter over conductor and the min./max. diameter over insulation are observed.
- Values shown in table are for round multiwire (RM) conductors. Values on request for round solid (RE) and round fine stranded (RF) as well as enameled wires conductors.
- Individual variant number specified with a configurator based on cable data

### Example illustration: CONNEX size 6 cable connection system

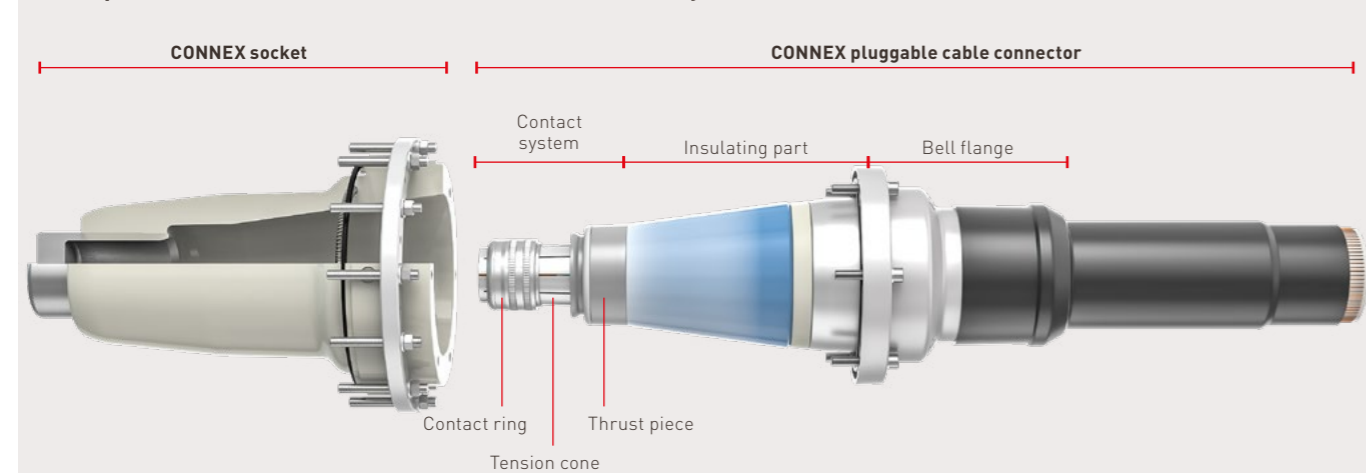

### CONNEX pluggable cable connector – the right connector for every cable

PFISTERER accessories are configured cable-specifically. The blue QR code at the bottom right takes you to all relevant parameters for the CONNEX cable connector.

The most important parameters for the CONNEX cable connector you can already see here:

- Voltage level (kV): \_\_\_\_\_  
Defines the size of the cable connector
- Application: Indoor   
Outdoor  Low temperature  Offshore   
Defines the complementary tools
- Link box connection: Yes  No   
If yes, diameter of the bonding cable (mm): \_\_\_\_\_
- Diameter over conductor in mm: \_\_\_\_\_  
Defines the contact system of the cable connector
- Diameter over insulation in mm: \_\_\_\_\_  
Defines the complementary tools
- Type of cable screen
- Cross-section of the cable screen: \_\_\_\_\_  
Defines the insulating part of the cable connector
- Type of armoring  
(wire or tape armoring): \_\_\_\_\_  
Defines the complementary tools

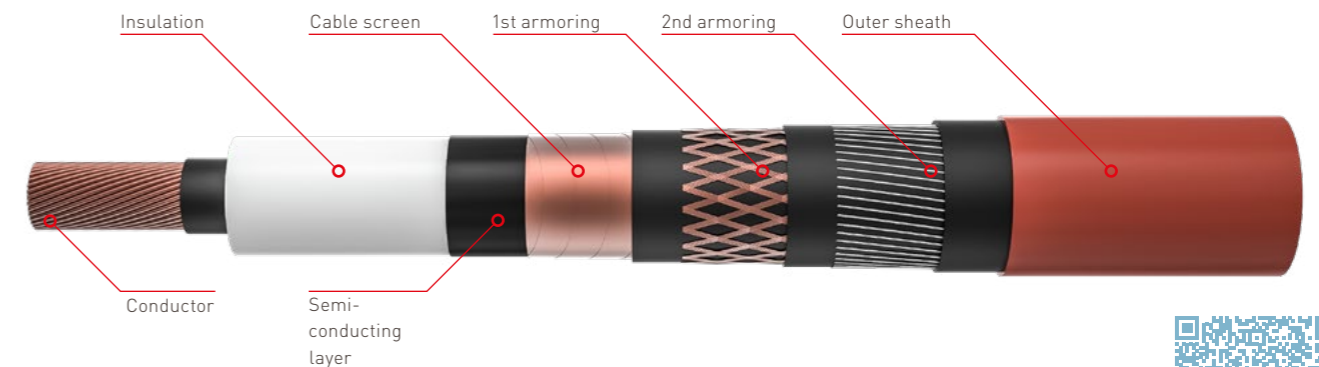

You can find the configuration form for the CONNEX cable connector on our website under Downloads.

### Rotatable bell flange

The rotatable bell flange enables pre-assembly, for example, since the cable does not have to be rotated during installation.

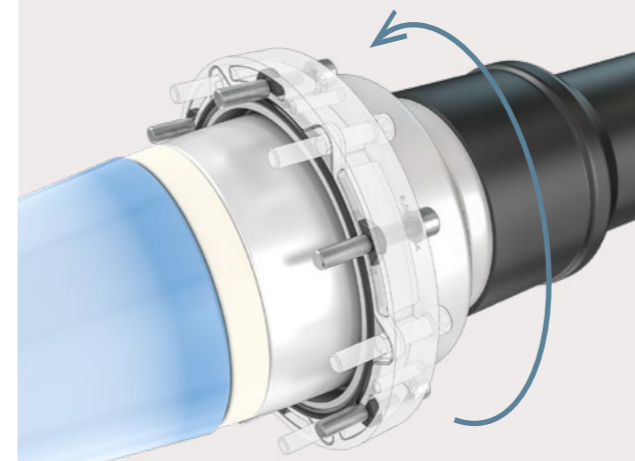

### Cable screen treatment individually adapted to the cable design

With pre-assembled SMART clamp, certain common types of screen connection can be implemented easily and reliably.



## 2.3 CONNEX pluggable surge arrester



The arrester range is used to protect metal-enclosed switchgear (GIS) or transformers equipped with CONNEX sockets. The surge arrester is installed directly on the switchgear or transformer, and prevents unacceptably high overvoltages from entering.

The insulation and stress grading of the CONNEX surge arrester are made of solid silicone, and thus do not contain any environmentally relevant liquids or insulating gases. Where there is no internal gas pressure, there are also no pressure vessel regulations to comply with, and gas monitoring is not required. In addition, the solid insulation enables a compact and therefore space-saving design.

### At a glance

- Protection of GIS and transformers against unacceptably high overvoltages
- Corrosion-resistant, suitable for outdoor and offshore use
- Hermetic encapsulation of the active components against environmental influences such as moisture or surface contamination
- Active component with metal oxide resistors, designed without spark gap
- High thermal stability of resistors
- Voltages up to  $U_m = 180$  kV
- Earthing systems: isolated/compensated or solidly grounded
- Routine tested before delivery



CONNEX pluggable surge arrester size 6

### Technical description

#### CONNEX pluggable surge arrester size 4

- External length from socket approx. 1000 mm
- Diameter 250 mm
- Weight 40 kg
- Environment: Offshore, outdoor and indoor
- Installation altitude up to 2000 m above sea level
- Operating temperature from -25 to +40 °C

#### CONNEX pluggable surge arrester size 6

- External length from socket approx. 1400 mm
- Diameter 400 mm
- Weight 88 kg
- Environment: Offshore, outdoor and indoor
- Installation altitude up to 2000 m above sea level
- Operating temperature from -25 to +40 °C

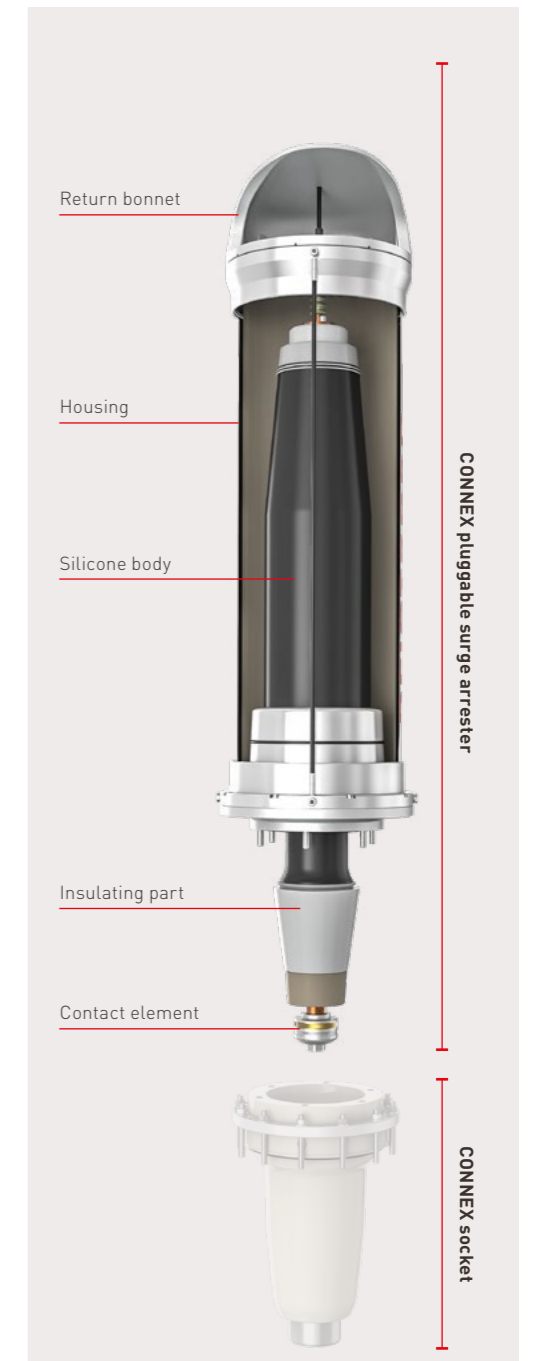

#### CONNEX pluggable surge arrester size 4

Max. rated voltage $U_r$ [kV]	Continuous operating voltage $U_c$ [kV]	Temporary surge		Max. residual voltage $U_{res}$ at						Article no.
		$U_{TOV}$ (1 s) [kV]	$U_{TOV}$ (10 s) [kV]	1/<20 $\mu$ s 10 kA [kV]	8/20 $\mu$ s 5 kA [kV]	8/20 $\mu$ s 10 kA [kV]	8/20 $\mu$ s 20 kA [kV]	30/60 $\mu$ s 125 A [kV]	30/60 $\mu$ s 500 A [kV]	
42.5	34.0	45.5	43.8	124.0	106.0	113.3	129.0	85.0	89.0	827 541 425
45.0	36.0	48.2	46.4	132.0	112.0	119.9	136.0	88.0	94.0	827 541 450
52.5	42.0	56.2	54.1	154.0	131.0	139.9	159.0	103.0	109.0	827 541 525
61.3	49.0	65.6	63.1	179.0	152.0	163.2	185.0	120.0	127.0	827 541 613
65.0	52.0	69.6	67.0	190.0	162.0	173.2	196.0	127.0	135.0	827 541 650
72.5	58.0	77.6	74.7	212.0	180.0	193.2	219.0	142.0	151.0	827 541 725

#### CONNEX pluggable surge arrester size 6

Max. rated voltage $U_r$ [kV]	Continuous operating voltage $U_c$ [kV]	Temporary surge		Max. residual voltage $U_{res}$ at						Article no.
		$U_{TOV}$ (1 s) [kV]	$U_{TOV}$ (10 s) [kV]	1/<20 $\mu$ s 20 kA [kV]	8/20 $\mu$ s 10 kA [kV]	8/20 $\mu$ s 20 kA [kV]	8/20 $\mu$ s 40 kA [kV]	30/60 $\mu$ s 1000 A [kV]	30/60 $\mu$ s 2000 A [kV]	
66	53	75	69	183	154	168	188	132	138	827 547 066
72	58	81	76	200	168	184	205	144	150	827 547 072
78	62	88	82	215	181	198	221	156	162	827 547 078
84	67	95	88	232	195	213	238	167	175	827 547 084
90	72	102	95	248	209	228	255	179	187	827 547 090
96	77	108	101	265	223	244	272	191	200	827 547 096
108	86	122	113	298	251	274	306	215	225	827 547 108
114	91	129	120	315	265	289	323	227	237	827 547 114
120	96	136	126	331	279	305	340	239	250	827 547 120
132	106	149	139	365	307	335	374	263	275	827 547 132
144	115	163	151	398	335	366	408	287	300	827 547 144
156	125	176	164	430	362	395	441	311	324	827 547 156
168	134	190	176	463	390	426	475	334	349	827 547 168
180	144	203	189	496	418	456	509	358	374	827 547 180



## 2.4 CONNEX pluggable bushing



The dry insulated CONNEX bushing with advanced plug connector technology has been part of the PFISTERER product range for more than 20 years, and offers lifelong very high user-friendliness. It is versatile for connecting transformers to bare conductors as well as to CONNEX elbow joints for numerous interim applications (see catalog part 3), while being swappable with CONNEX cable connectors at any time. In every application, the bushing is efficient to install as it plugs into CONNEX interface components integrated into transformers and CONNEX joints. This eliminates the need for time-consuming handling of liquid or gaseous insulating materials – especially oil work such as filling, drying and vacuuming.

Every installation and removal of the CONNEX bushing is performed without intervening in the inner workings of the equipment or joint. As a result, transformers fitted with CONNEX connectors can remain safely sealed in many sensitive situations: during factory testing and delivery, when connecting, and during commissioning tests at the place of use.



### At a glance

- For efficient flexible connection of bare HV conductors in many applications: Permanent or temporary connections on transformers, can also be plugged into CONNEX elbow joints for various interim applications (see catalog part 3)
- Dry, solid-insulated and with plug connector technology, therefore:
- Installation without handling liquid insulating materials, without intervention in equipment
- Swappable with other CONNEX components, e.g. cable connector
- Can be plugged multiple times – simplified transportation and handling
- Water and dirt repellent silicone insulator sheds
- Maintenance-free, no leakage or environmental risks, explosion-proof
- With voltage tap for measuring the loss factor ( $\tan \delta$ ) and capacitance
- Routine tested before delivery

### CONNEX pluggable bushing

Size	Standard	Type	Highest voltage $U_m$ [kV]	Nominal current $I_n$ [A]	Length from flange [mm]	Arcing distance [mm]	Creepage distance [mm]	Weight [kg]	Article no.
4	IEC	RIS	72.5	2000	960	600	2248	48	828 184 001
5-S	IEC	RIP	145	1250	1600	1300	4495	85	828 186 012
6	IEC	RIP	145	1250	1665	1250	4495	108	828 187 020
6	IEC	RIP	170	1250	1915	1500	5270	125	828 187 019
6-S	IEC	RIP	245	1250	2735	2300	7595	166	828 192 001
6	IEEE	RIS	138	1250	1665	1260	4836	108	828 187 021
6	IEEE	RIS	161	1250	1915	1500	5788	125	828 187 022

### Modern insulation types: Resin Impregnative Synthetics (RIS) and Resin Impregnated Paper (RIP)

Resin impregnated synthetics is the latest technology in the high voltage field. It is very similar to resin impregnated paper (RIP) technology, but with one exception: instead of using conventional paper as a spacer between the capacitive layers, plastic fabric is wrapped around the core of the bushing. Both RIP and RIS bushings use epoxy resin as the main insulating material. The shielding is made of silicone rubber.

### CONNEX bushing system

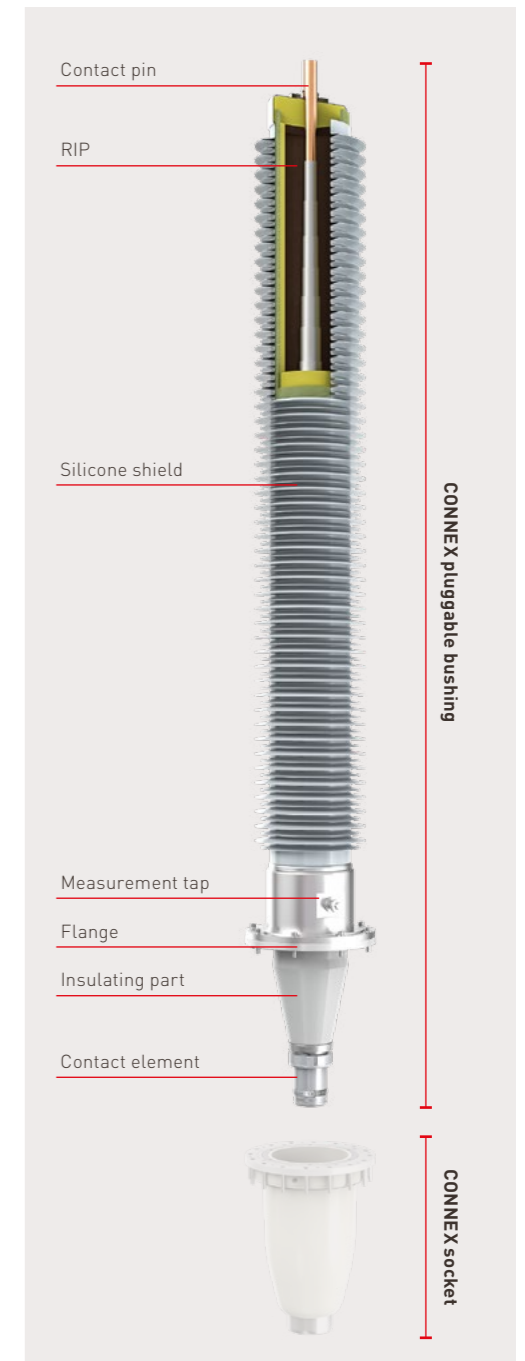
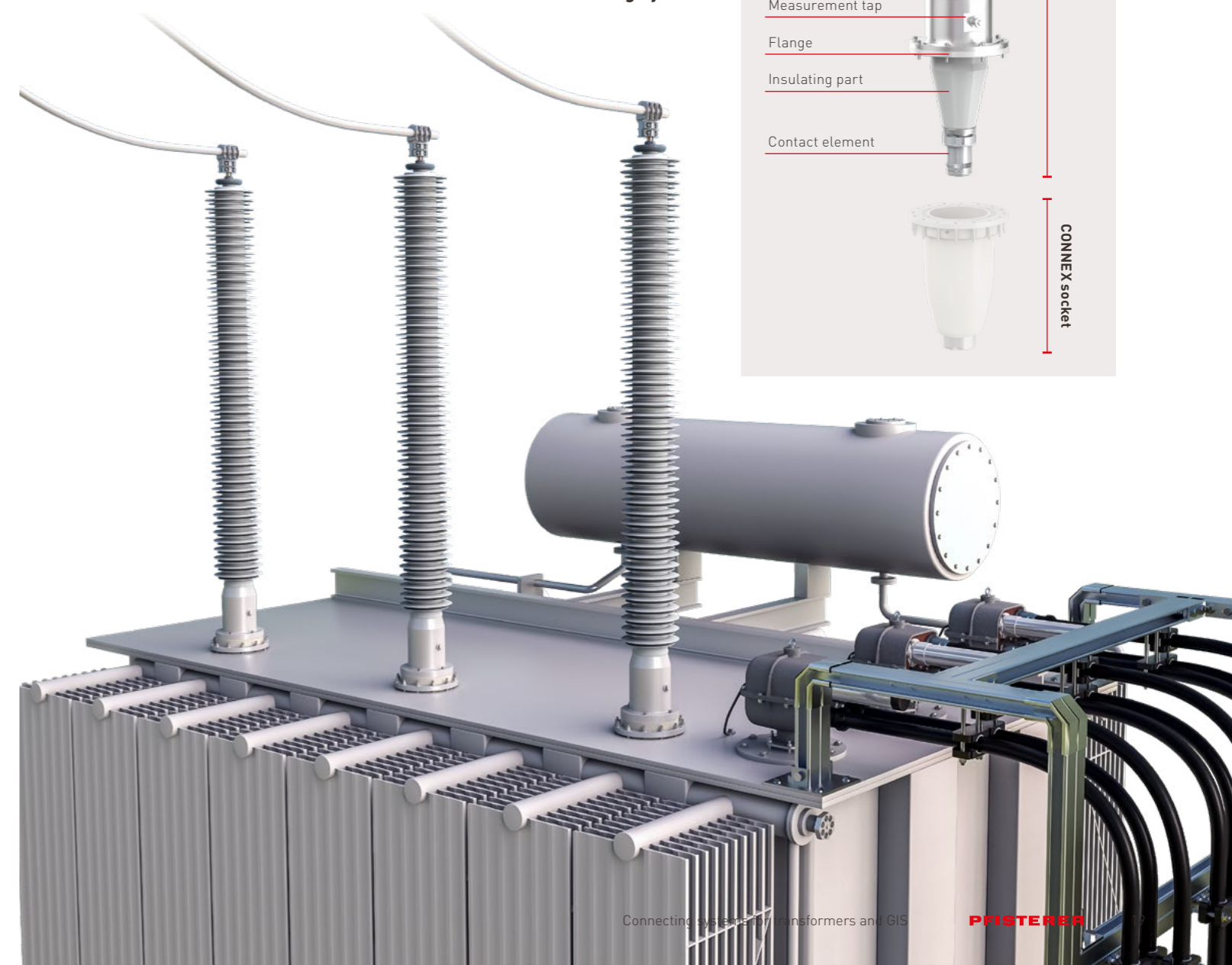

# 2.5 Gas-insulated bushings



Gas-insulated bushings from PFISTERER are economical and reliable technology for single-pole outdoor connections from gas-insulated switchgear (GIS) to air-insulated switchgear and overhead lines.

Our comprehensive range of services enables product service tailored to needs: consultation, development and simulation. Production and testing of each individual bushing to applicable IEC standards as well as customer specifications.

PFISTERER offers customized solutions for all GIS applications. Depending on the application and environmental conditions, silicone or ceramic bushings are used. The compact design allows an economical use of insulating gas.

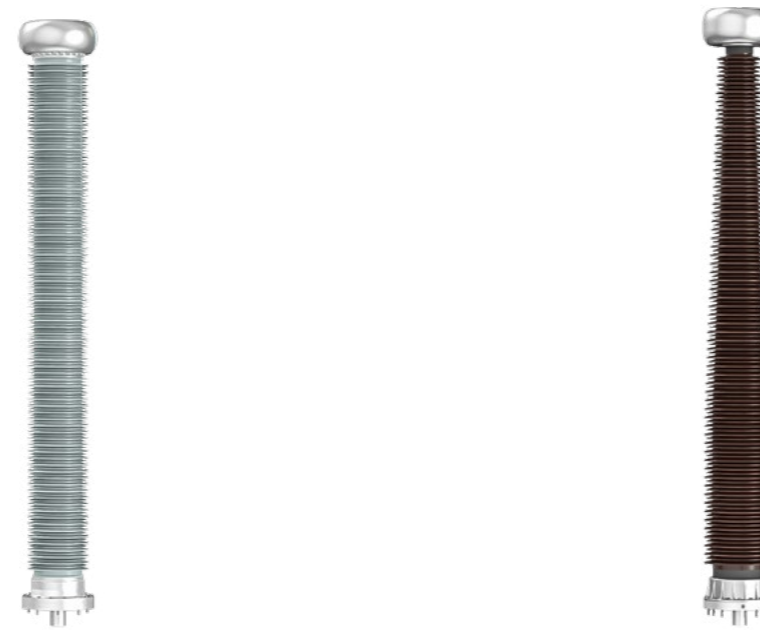

### Silicone bushings

These are lighter than comparable ceramic bushings and also breakage resistant under shock stresses.

The hydrophobicity of the silicone rubber material is one of its key properties: It causes moisture to bead and run off the surface, prevents the formation of a water film, and reduces the buildup of dirt – both of which could otherwise lead to creepage currents and in the worst case flashovers.

#### At a glance

- Lightweight solution
- Able to withstand high shock loads
- Key property: hydrophobicity
- High degree of safety and security
- Routine tested before delivery

### Ceramic bushings

Ceramic has been established as an insulation material for over 100 years. Ceramic bushings are still standard in many core markets, for example the Middle East.

Due to their dimensional rigidity, they exhibit higher mechanical strength than silicone bushings. Plus they are highly resistant to surface degradation in the event of partial discharge. In contrast to silicone bushings, no conductive path can form in the event of partial discharges or flashovers.

Among other things, this results in a very long service life for ceramic bushings.

#### At a glance

- Established material
- References in various core markets
- Higher mechanical strength than silicone bushings
- Extremely durable
- Ceramic insulator is not hazardous waste on disposal
- Routine tested before delivery

### Gas-insulated bushings – silicone

Highest voltage $U_m$ [kV]	Nominal current $I_n$ [A]	Rated short-time withstand current [kA] / duration 3 s	Rated power frequency withstand voltage, dry [kV]	Lightning impulse withstand voltage (BIL), dry [kV]	Switching impulse withstand voltage (SIL), wet [kV]	Arcing distance [mm]	Minimum nominal creepage distance [mm]	Design cantilever load [N]	Minimum gas pressure [kPa abs.]	Rated filling pressure [kPa abs.]	Design pressure [kPa abs.]	Gas volume [l]	Weight [kg]	Temperature range [°C]	Article no.
72.5	2500	36	140	325	-	737	2420	1575	450	530	870	28	56	-40 - 40	71 740 YYYY XXXX
145	3150	63	275	650	-	1512	5560	3500	750	790	950	75.4	80	-50 - 40	71 740 YYYY XXXX
245	3150	80	460	1050	-	2312	8630	2500	450	530	870	111	107	-40 - 40	71 740 YYYY XXXX
300	3150	80	460	1050	850	2612	9780	2500	450	530	870	125	118	-40 - 40	71 740 YYYY XXXX
420	4000	100	650	1425	1050	3962	14954	2500	450	530	870	384	265	-40 - 40	71 740 YYYY XXXX
550	5000	63	860	1800	1175	5714	21850	2500	400	480	900	1100	602	-40 - 40	71 740 YYYY XXXX

### Gas-insulated bushings – ceramic

Highest voltage $U_m$ [kV]	Nominal current $I_n$ [A]	Rated short-time withstand current [kA] / duration 3 s	Rated power frequency withstand voltage, dry [kV]	Lightning impulse withstand voltage (BIL), dry [kV]	Switching impulse withstand voltage (SIL), wet [kV]	Arcing distance [mm]	Minimum nominal creepage distance [mm]	Design cantilever load [N]	Minimum gas pressure [kPa abs.]	Rated filling pressure [kPa abs.]	Design pressure [kPa abs.]	Gas volume [l]	Weight [kg]	Temperature range [°C]	Article no.
72.5	3150	80	140	325	N/A	800	2900	3500	450	530	900	29	133	-40 - 40	71 629 YYYY XXXX
145	2500	80	275	650	N/A	1590	4496	2000	450	550	900	32	160	-40 - 40	71 629 YYYY XXXX
245	3150	50	460	1050	N/A	2300	7812	2500	600	680	870	80	271	-30 - 40	71 629 YYYY XXXX
300	3150	63	460	1050	850	2540	9990	2500	450	530	870	154	432	-40 - 40	71 629 YYYY XXXX
420	4000	63	650	1425	1050	4350	17593	2500	450	530	900	330	856	-40 - 40	71 629 YYYY XXXX
550	4000	63	710	1550	1175	4610	15546	2500	390	460	870	590	1057	-40 - 40	71 629 YYYY XXXX

## 2.6 CONNEX complementary tools



### Solid-insulated dummy plug

For sealing and voltage-proof closing of CONNEX sockets that are installed on transformers and gas-insulated switchgear (GIS). Suitable for continuous operation, voltage tests and offshore use.



### Solid-insulated dummy plug

Size	Highest voltage $U_m$ [kV]	Article no.
4	72.5	827 700 004
5-S	145	827 701 002
6	170	827 706 013
6-S	245	827 706 014
7	300	827 706 005
7-S	362	827 706 006

### Gas-insulated blind cover

For sealing and voltage-proof closing of CONNEX sockets that are preinstalled in GIS with SF<sub>6</sub> filling of the socket. The blind cover can be used for voltage tests, particularly for demanding GIS testing at manufacturers' works and in test laboratories. Not suitable for continuous operation or offshore use.



### Gas-insulated blind cover

Size	Highest voltage $U_m$ [kV]	Article no.	
		with manometer	without manometer
4	72.5	827 714 011	827 714 012
5-S	145	827 711 011	827 711 012
6 / 6-S	245	827 716 001	827 716 012
7 / 7-S	362	827 717 001	-
8	420	827 718 011	-



### Current testing plug

This plug can be used to carry out current tests on CONNEX sockets in transformers and GIS.

### Current testing plug

Size	Nominal current $I_n$ [A]	Max. testing voltage $U_m$ [kV]	Article no.
4	1600	5	827 093 004
5-S	1600	5	827 093 005
6 / 6-S	1600	10	827 093 006
7	4000	10	827 093 007
8 / 9	4000	10	827 093 008

### Earthing and short-circuiting device

This device is used to earth and short-circuit GIS and transformers fitted with CONNEX sockets.



### Earthing and short-circuiting device

Size	Article no.
4	827 086 004
5-S	827 086 005
6 / 6-S	827 086 006



## 2.6 CONNEX complementary tools



### Cable support system

The cable support system is used for the permanent centric fixing of cables that are connected with CONNEX cable connectors to equipment-side integrated CONNEX sockets.

#### At a glance

- For permanent centric cable connection
- Pre-assembled
- Can be retrofitted to an already plugged in cable connector
- Suitable for offshore use

#### Cable support system 1

Size	Length L [mm]	Cable diameter range Ø [mm]	Article no.
6 / 6-S	826	50 - 200	827 810 110
6 / 6-S	1450	50 - 200	827 810 100
7 / 7-S	1450	50 - 200	827 810 101

#### Cable clamp set 2

Cable diameter range Ø [mm]	Article no.
50 - 75	562 438 001
75 - 100	562 438 003
100 - 130	562 438 002
130 - 160	562 438 004
160 - 200	562 438 005

Cable clamp set matched to cable diameter. To be ordered separately.

#### Assembly, earthing and protective cap

The assembly cap allows the CONNEX cable connector to be pretensioned and heat-shrunk. It is then fully pre-assembled ready for final installation. This is done by plugging it into a CONNEX socket on GIS or on a transformer. The assembly cap also serves as an earthing cap and protective cap.

#### At a glance

- Three functions in one tool: Installation, earthing and protection
- Pre-assembly can be carried out anytime, at any suitable location
- For protection against damage as well as ingress of liquids and solids
- Suitable for offshore use

#### Assembly, earthing and protective cap

Size	Article no.
4	827 174 104
6 / 6-S	827 174 106
7 / 7-S	827 174 107



### Cover disk

Protects unused CONNEX sockets on transformers and GIS against damage and ingress of liquids and solids, for example rainwater when used outdoors.

#### At a glance

- For protection against damage as well as ingress of liquids and solids
- Suitable for offshore use
- Included in the scope of delivery for standard orders of CONNEX sockets and CONNEX joints (catalog part 3)
- Not voltage-proof

#### Cover disk

Size	Article no.
4	827 220 104
5-S	827 220 105
6 / 6-S	827 220 106
7 / 7-S	827 220 107
8 / 9	827 220 108

### Protective cap

Protects unplugged CONNEX cable connectors that are already fitted on the connection cable or test cable, also pluggable CONNEX bushings and surge arresters, for example from rain when used outdoors.

#### At a glance

- For protection against damage as well as ingress of liquids and solids
- Use recommended during storage and transportation
- Included with CONNEX bushings and pre-assembled HV cables (with standard order)
- Not voltage-proof

#### Protective cap

Size	Article no.
4	827 708 011
5-S	827 708 012
6 / 6-S	827 708 013
7 / 7-S	827 708 014
8 / 9	827 708 015



## Control current and voltage. Speed up installation.

**Pluggable connection components that are dry-insulated with solids are increasingly being used in new and existing equipment worldwide. Thanks to many advantages** over products filled gases or liquids (for details see the following pages).

**The CONNEX connecting and jointing system from PFISTERER is a pioneer and driver of this progress.** With what was once the world's first pluggable cable connection based on the inner cone system. And is a product family for medium to extra high voltage that has been continuously developed ever since.

**The lifelong reliable functioning of CONNEX components is based on fundamental electrical engineering principles and quality criteria. Examples of their implementation are described on the next six pages along with parts of the most commonly used CONNEX components:**

The CONNEX cable connector and the CONNEX socket. Together, they form a pluggable cable connection with multiple advantages: it can be installed safely, faster, without the time and effort of using gaseous or liquid insulating media. Can be disconnected at any time and connected repeatedly.

**Innovative contact technology makes even wire-strand insulated cables safely and quickly pluggable. You can see exactly how on pages 32 and 33, illustrated with the CONNEX cable connector equipped with FrontCon contacting technology by PFISTERER.**

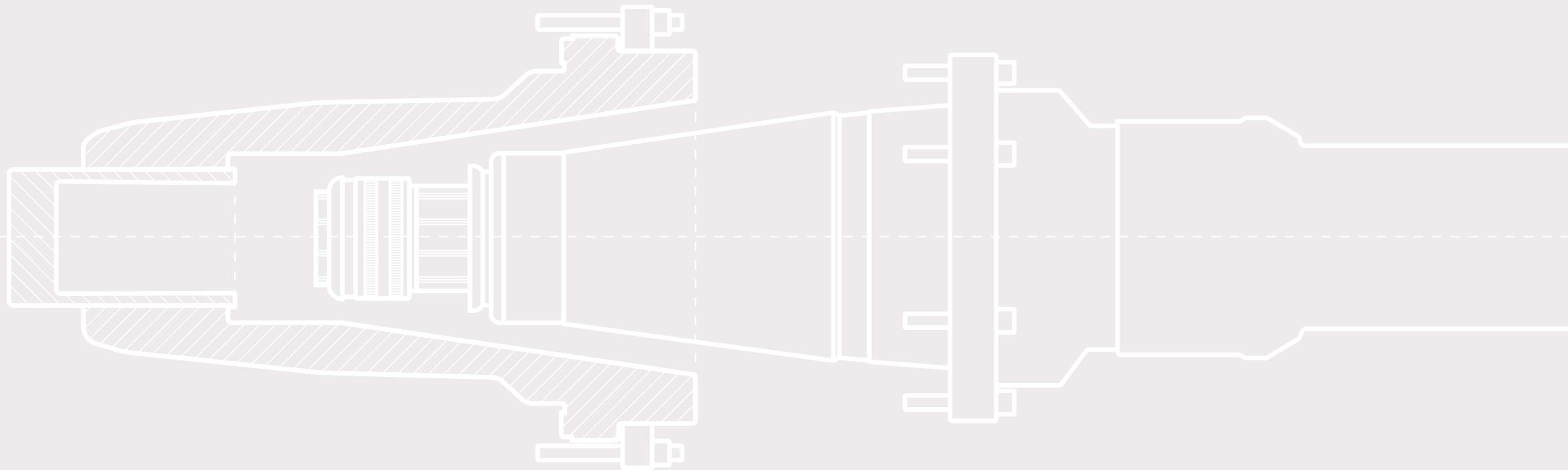

## 3.1 Reliable in operation: Effective under current



Transfer high currents effectively. Safely insulate high voltages. Control electric fields. The CONNEX cable connection system ensures these essential functions using proven modern means in a highly compact design. Exemplary design details are explained below. With internal views of the cable connector in conjunction with the CONNEX socket. And with a look at general requirements for plug connectors.

### Sensitive factors for current flow

**The current-carrying contact elements are key parts of the connection components.**

It is decisive for their lifelong functionality that the contact resistance remains as low as possible at the contact points. For this, the contact elements must provide a sufficiently effective contact area in relation to the current intensity. Otherwise high contact resistances will occur, accompanied by an impermissibly high temperature rise, which, if it occurs repeatedly, will accelerate natural contact aging, impede the current flow and, in the worst case, thermally destroy components.

**For contact resistance to remain uncritical, various physical factors must be taken into account in the contact design. Important among other things:**

**Surface roughness.** This becomes visible under the microscope: Surfaces of contact elements are uneven, with peaks and valleys. Consequence: Only a fraction of the overlapping area of contact pieces touches a few potential contact points. This can make it difficult for current to flow – with the risk of high contact resistances. As a countermeasure, force is applied to the contact elements during contacting. This pushes the peaks on the material surfaces into each other, and thus directly establishes the important galvanic contact.



**Loss of force.** Over time, the applied contact force decreases as a result of various physical influences. However, for decades of trouble-free current transmission, a minimum contact force must be permanently maintained. Elastic or spring elements can compensate for the declining contact force – with their own elasticity.

**Surface corrosion.** Contact points come into contact with oxygen in the air – with a reaction potential. An oxide layer can form. It has an insulating effect and increases the resistance. The use of precious metals prevents oxidization on contact elements. Deposits on cable conductors can be overcome mechanically when electrical contact is established.

**In addition, the specific advantages of solid insulated pluggable components influence the contact design.** They are significantly more compact than oil-insulated connection components. Accordingly, less space is available for the required contact area. What also distinguishes dry plug connectors: They can be disconnected and repeatedly connected. This requires contact elements that interlock powerfully, while at the same time being separable from one another.



### Contact quality versus resistance

**These and other requirements are reflected in the classic contact system of CONNEX cable connectors.**

In the CONNEX cable connector, the tension cone [1] and contact ring [2] establish electrical contact with the cable conductor. The contact ring [2] and its precisely fitting counterpart in the CONNEX socket – the contact socket [3] – form the current bridge to the equipment.

**The contact force** is introduced into the contact system during installation by inserting the cable connector into the socket. The overall design of the CONNEX cable connector keeps the force at a high level for life. The individual contact elements are surface-finished with silver, preventing surface contamination. Together, they form permanently effective contact surfaces with a defined size and long-term quality. Thanks to the use of different tried-and-tested contact types at the appropriate point in the contact system. Two examples:

Contact with the cable conductor is established via **line contacts**. These are created when the cable connector is installed on the cable by clamping the contact ring [2] on the tension cone [1]. This presses the inner thread of the tension cone against the cable conductor. The thread faces penetrate any oxide layers and press against the conductor surface with a controlled force, forming defined linear contact points.

**Lamella contacts** are characteristic of plug connectors and consist mainly of conductive contact lamellas: robust strips made of a surface-treated alloy, specially shaped and arranged numerous in parallel on bands [4]. In the CONNEX cable connector, one or two of these bands are fitted, depending on the component size. They are fixed around the contact ring in guides for current transfer between the cable connector and socket. The contact lamellas flexibly move with the force-introducing plugging-in process. When the cable connector is inserted into the tapered socket, the lamellas press against the contact sleeve in the socket. Thanks to their own spring force, each lamella makes optimal contact with the contact socket – without mechanically penetrating into it. As a result, their excellent conductive connection remains detachable at all times. As long as the connection remains in place, the lamella contacts ensure low total resistance and therefore continuously good current flow.

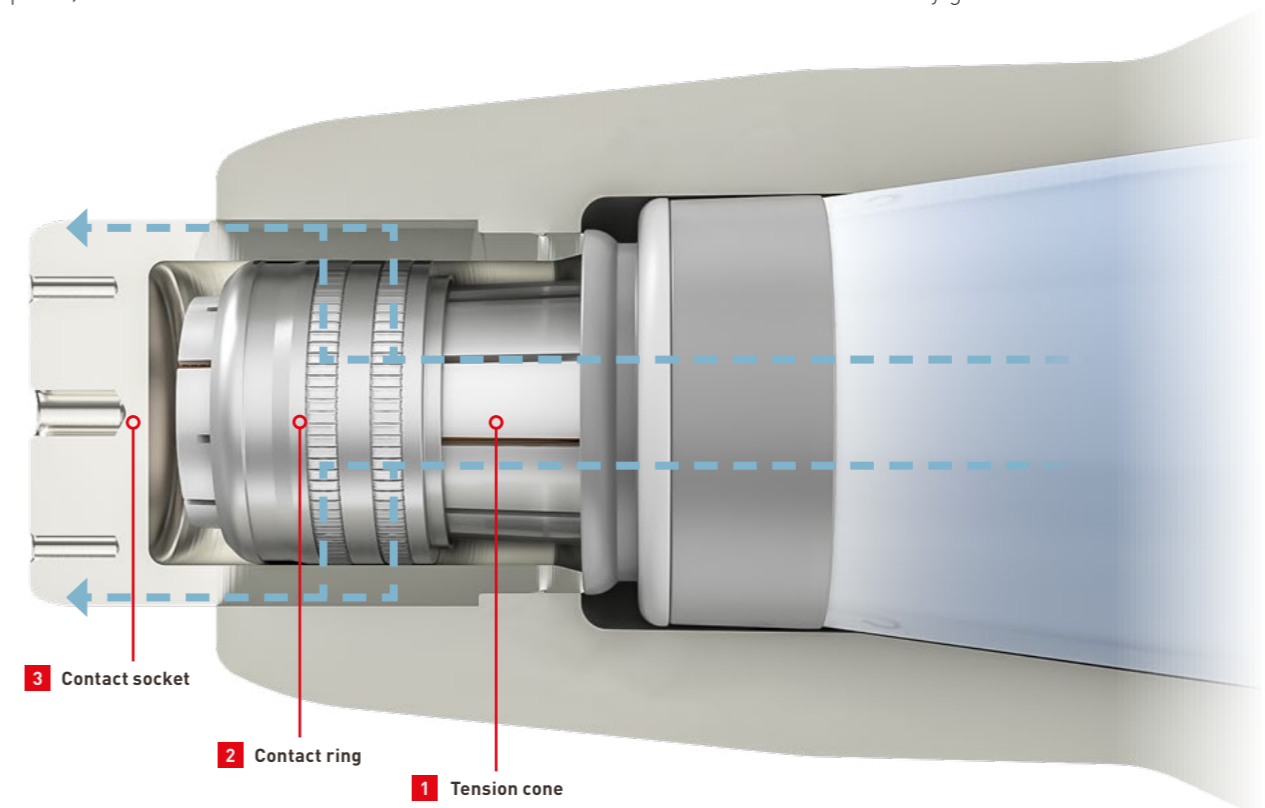

# 3.1 Reliable in operation: Safe under voltage



## Constant and flexible for safe insulation

The high voltages in the CONNEX cable connector are dry insulated with components made of high-quality silicone – mainly the advanced LSR type (Liquid Silicone Rubber) or as a special RTV variant (Room Temperature Vulcanizing).

The material and design work together for lifelong reliable insulation.

The insulating silicone body of the CONNEX cable connector is conically shaped [5] to match the inner cone of the CONNEX socket. This allows the insulating body to fit in seamlessly when the cable connector is plugged into the socket, and effectively converts the force applied into all-round contact pressure against adjacent components, with the socket applying counterpressure. **This results in gap-free insulating surfaces between the insulating part and socket (outer insulating sealing surface) [6] as well as between the insulating part and cable (inner insulating sealing surface) [7].**

**Their preservation over several decades of service life is ensured by differentiated material properties and components:** The silicone formulation is adapted for equally good insulating ability and elasticity of the insulating body. A spring [8] at the base of the insulating part ensures its constant contact pressure – with room to move for thermal breathing:

Due to varying current loads and ambient temperatures, the cable and connector are exposed to extreme temperature fluctuations. When heated, the conductor expands, while the insulating body elongates. As they cool, the conductor contracts and the insulating body shortens. Accordingly, the spring acts with precision: it yields or pushes forward. As a result, the insulating part is able move in a controlled manner. Without risk of permanent deformation of the insulating part due to lack of space. Without reducing its contact pressure, which would weaken the insulation.

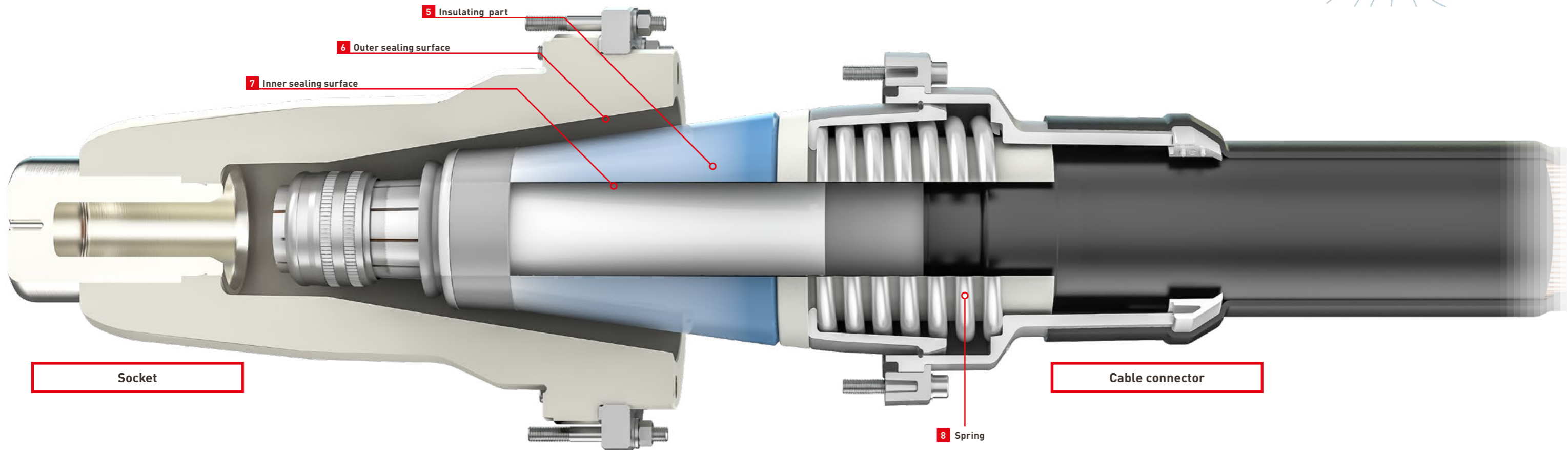

# 3.1



## Geometric stress grading against critical field strengths

**Stress grading is another function located in the insulation areas of CONNEX cable connector and socket. It is fundamental for the reliable operation of the cable connection:** By reducing local excessive electrical field strength, it prevents destructive electrical breakdowns.

Excessive field strengths occur where there are unevennesses, voids or transitions between conductive components and insulating media. A typically susceptible area in cable accessories is the cable end. Its insulation is exposed for attachment of the accessory, and the covering outer semiconductor layer ends with sharp edges. Without field control measures here, the field lines would run in such a way that would result in an increased stress in this area.

**In cable accessories for high voltages, the stress grading is usually implemented geometrically with semiconducting control components, known as deflectors. This is also the case with CONNEX cable connectors.**

Several design factors are decisive for the effectiveness of the deflectors: Their precise placement in areas of potential excessive field strength. Sufficient deflector volume to implement the optimal deflector contour. The contour steers the field line trajectories in such a way that the field strength remains uncritical.

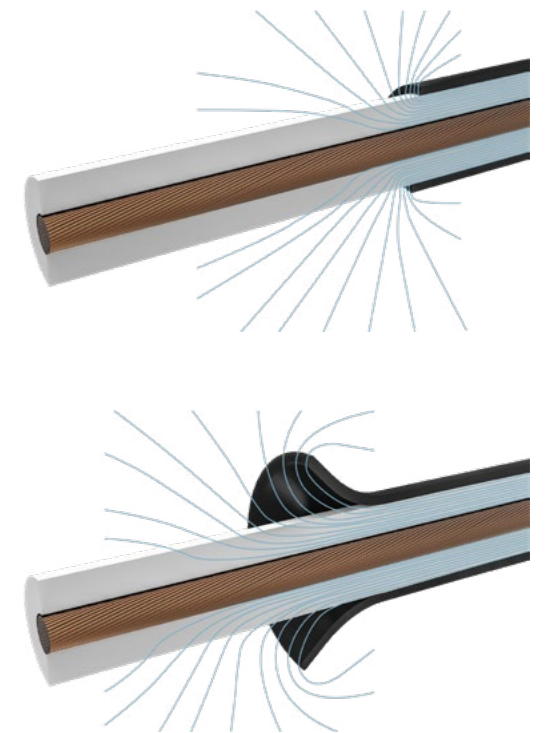

## 3.2 Uniquely efficient with FrontCon: Connecting complex cable

3.2



With CONNEX cable connectors, specialist fitters install any plastic insulated cable faster and more safely. Even complexly structured cables with enameled wires conductors – thanks to FrontCon technology.



FrontCon is an innovative contact technology from PFISTERER specifically for enamelled conductors. It can be integrated into various PFISTERER accessories, including CONNEX cable connectors, instead of the classic CONNEX contact system elements described on page 29.

**FrontCon considerably simplifies cable connector installation.** Extremely time-consuming work steps are completely eliminated, as are the associated risks of installation errors. **Instead of entire days, installation takes only about two hours per cable connection** – the same as for conventional cables with standard connectors.

### 80% faster installation with minimized risk of errors

Conventional connection of a single-wire insulated conductor requires a lot of patience and very detailed work: after stripping the cable, you have to spread out the conductor, remove the insulation from its wires individually, sand them bright and then restore them to approximately their original shape and position.

### Better with FrontCon. The contact system involves comparatively simple installation steps:

- Saw off the cable end squarely
- Remove outer cable insulation (stripping)
- Clamp the FrontCon contact system centrally and with stable pressure onto the expose single-wire bundle
- Pour FrontCon contact balls into the connector
- Tighten the pressure screw

### Smart contacting – with balls and springs

The pressure screw presses the FrontCon contact balls against the single-wire conductors, thus establishing electrical contact. Power flows via the front faces of the conductor wires and the contact balls.

Together, the balls behave like a liquid:

They compensate for slight unevenness at the conductor ends, thus ensuring consistently strong contact forces across the whole conductor cross-section.

A built-in spring mechanism plays a supporting role. It compensates for settling losses caused by expansion and contraction of the cable due to operational and environmental temperature fluctuations – with important long-term effects for lifelong reliable operation: low contact resistances and stable contact forces over the entire service life.

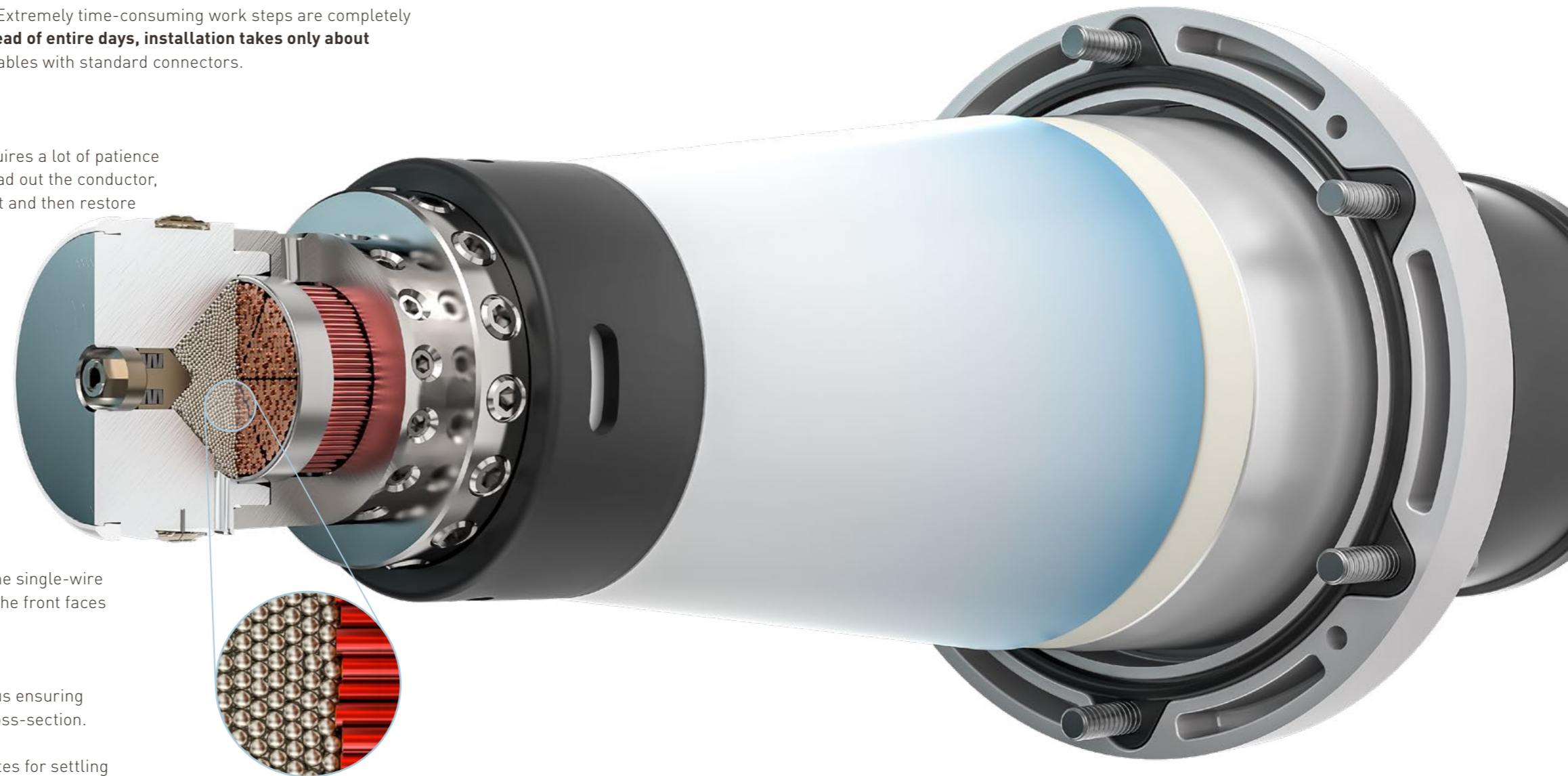

**Conclusion: With FrontCon, you reduce the time, effort, risks and costs of installation and get higher operational reliability plus reliable longevity.**

**The correct installation of PFISTERER accessories for high and extra high voltage is taught professionally and in a practice-oriented way in obligatory training courses. Find out more on page 42.**

## Equipped for many cases and locations. With quality in diversity from a single source.

Transformers and gas-insulated switchgear (GIS) for high voltage are individually designed capital goods. Equipped with PFISTERER solutions, they are not only consistently reliable, but also versatile, safe and secure to use:

On cables and overhead lines. Under normal and difficult environmental conditions. In buildings or outdoors. Stationary operation, moving between construction sites, on call as a reserve. Underground or at altitude. At sea, in the center of town.

Different uses for PFISTERER accessories are shown on the following three double pages. On GIS and transformers as well as in permanent and temporary cable sections. With products from all three PFISTERER catalog parts for HV and EHV accessories. Based on the CONNEX system, the most comprehensive pluggable product family on the market for voltage levels from 6 kV to 550 kV. Connectable to and combinable with numerous other advantageous HV solutions from PFISTERER. **See for yourself.**



## 4.1 CONNEX in the city:

### Saves space. Cuts costs. Protects assets.

Limited space and increased safety requirements – the operation of high voltage equipment in urban areas presents a particularly tough challenge. With the CONNEX system, you have a powerful means of implementing the technically and economically optimal installation of GIS and transformers in these scenarios. Thanks to numerous pluggable CONNEX components for different connection and protection concepts.

#### Lean construction and operation

CONNEX supports compact device designs, starting with the inner workings: The CONNEX socket as a device-side component interface takes up less installation space than solutions insulated with oil or gas. As a result, cable connection boxes for GIS and transformers can be made smaller. Transformers can be even more compact: CONNEX sockets can be integrated directly into the casing, so bulky junction boxes for the phase connections can be dispensed with. If traditional air-insulated terminations are replaced with dry, fully insulated CONNEX cable connection systems consisting of socket and cable connector, neither minimum distances between phase connections and phase-to-earth nor complex busbar structures are required. In addition, CONNEX cable connectors can be mounted in all installation positions, which facilitates precise equipment integration in confined operating spaces.

#### Safe and secure for life and property

Added safety for indoor power equipment operation can result from the end-to-end use of CONNEX cable connection systems. This is because cable connections on the medium and high voltage side can be made touch-safe, and therefore fully and safely accessible for maintenance personnel without barriers. Full insulation of the CONNEX cable connections prevents a small animal from bridging two phases. GIS terminal boxes no longer have to be sealed off. Cumbersome fencing, as is usual around air-insulated transformer terminations, is not needed.

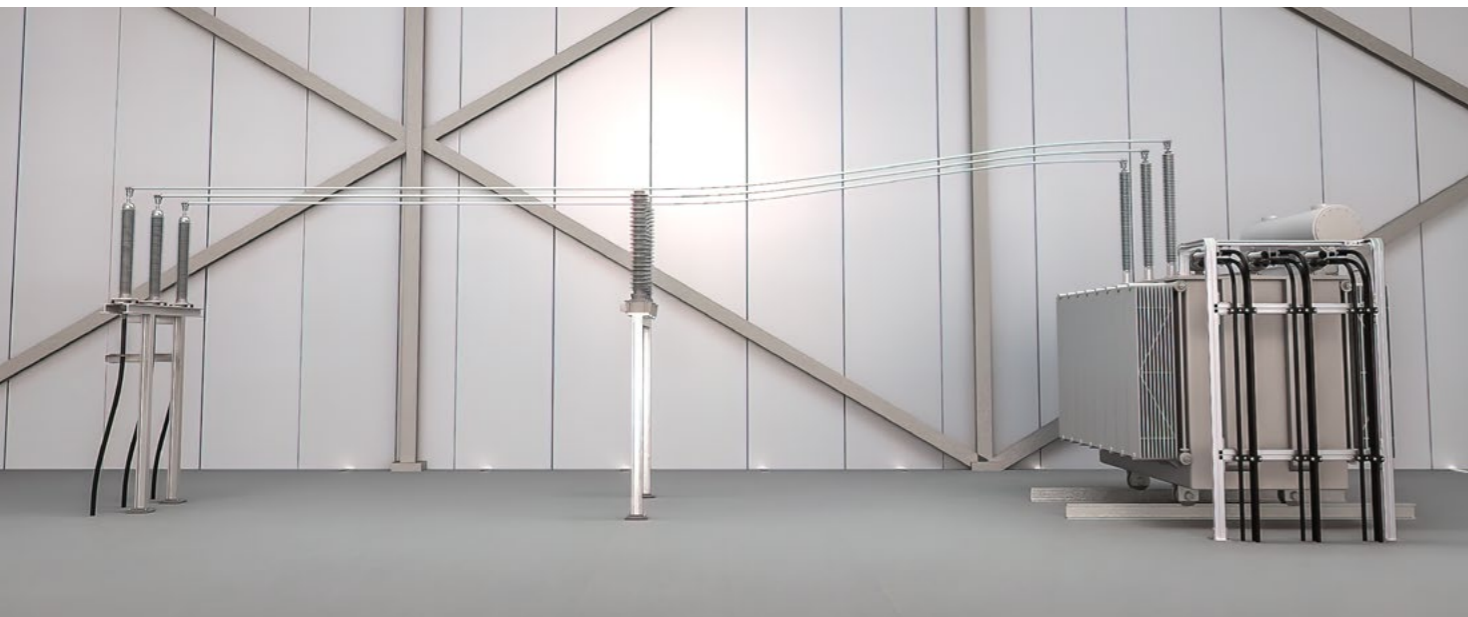

## 4.1



#### Optimum protection against overvoltages

The CONNEX surge arrester provides ideal surge protection in compact form. Dry insulated, it is slimmer than conventional gas-insulated models for GIS. CONNEX arresters save even more space when used on transformers (picture on the right): They completely replace space-consuming air-insulated solutions for surge protection (picture on the left). CONNEX arresters offer optimum protection for both GIS and transformers: Since they are placed directly on the equipment, in its junction box or in its housing, they provide the best possible protection. This is because the traveling wave character of transient overvoltages generally limits the protection radius of arresters.

#### Economical, with foresight

The range of CONNEX components enables the implementation of different connection and safety concepts for space-saving equipment and substations. With far-reaching effects: Instead of high costs for large properties in city center locations, other investments are possible: prestigious architecture, civil engineering works, new technologies. CONNEX components are already in use on switchgear with eco-efficient insulating gas.

CONNEX supports value preservation in every type and design of power equipment: Once equipped with CONNEX sockets as component interfaces, transformers and GIS are ready for use in any possible scenario in the near or distant future.

Example: If it is foreseeable that equipment will be moved from an outdoor application to an indoor application, it can at first be connected to an overhead line using a pluggable CONNEX bushing, and then later changed to CONNEX cable connectors – all without complex and risky interventions in the equipment.

The next two pages show further possibilities for making equipment utilization more flexible with CONNEX components.



## 4.2 Equip devices variably.

## 4.2

### For efficiency in operation and testing.

With CONNEX, you can test transformers and gas-insulated switchgear in many ways and connect them to the grid. Resulting in lifelong efficient use in various scenarios. With minimized expenses and reduced risks in every case. Thanks to the pluggability and diversity of CONNEX components, combinable with other proven PFISTERER high voltage accessories.

#### Versatile interface for many components

The mother of all possible applications for the CONNEX system is the socket, installed in transformers or gas-insulated switchgear (GIS) as a fixed interface for all CONNEX component types. Each is pluggable, and therefore can be mounted safely and quickly on the CONNEX socket, and is likewise interchangeable – without oil or gas work, without interventions in the equipment or components (for details see pages 8 and 9). With many positive effects:

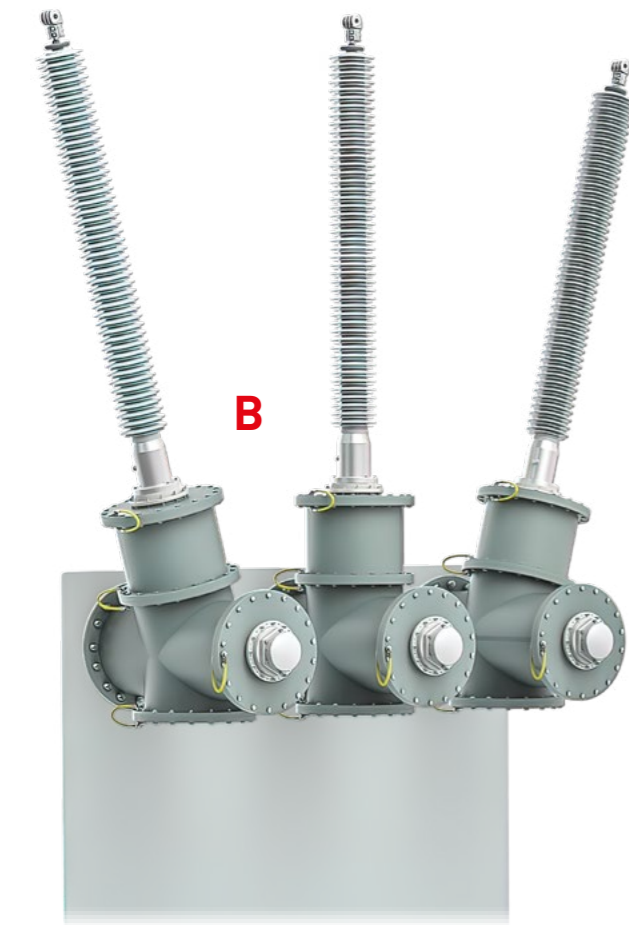

#### Closed for protection. Open for options.

GIS and transformers can remain closed in many situations usually associated with component assembly or dismantling: During factory testing and delivery, during transportation, during connection installation and commissioning tests at the site. Likewise during any component replacement in the course of the operating life. Two examples: When bushings are due for replacement after 20 or more years, the old bushings are unplugged and the new ones plugged in – into the existing sockets as they are. The same applies to grid remodelings: if the equipment is no longer to be connected to the overhead line, but via cables, CONNEX bushings can be replaced with CONNEX cable connectors.

#### Variable use of star points

Additional flexibility for protective measures on the transformer is gained by equipping its star point / neutral point with the CONNEX socket: For grounding precautions, a CONNEX cable connector can be plugged in. Star point can be isolated with a CONNEX surge arrester or a CONNEX dummy plug. To connect the transformer star point to a Petersen coil for line to ground fault current limitation in compensated grid topology, either a CONNEX pluggable bushing or a CONNEX cable connector can be used.

#### Flexible from equipment to cable route

Pluggable interfaces are also an integral part of all CONNEX joints (catalog part 3). The ability to combine CONNEX solutions with other PFISTERER accessories results in a wide range of options for connecting equipment directly or indirectly to test transformers or to the grid. This double page shows a selection with illustrated PFISTERER products from all three catalog parts for high voltage accessories.

With gas or solid insulated CONNEX joints [A, D, E], cable connections can be arranged straight or at right-angles, also easily and safely using plug-in technology. The joints with gas-insulated joint body [A, D] enable the simulation of switchgear applications for testing purposes.

Connection to a test transformer is possible, for example, using CONNEX bushings [B] or flexible PFISTERER terminations with or without support [C, F]. CONNEX dummy plugs provide a voltage-proof seal for unused sockets [G] – until the next use of the interface for the CONNEX component that is then required.

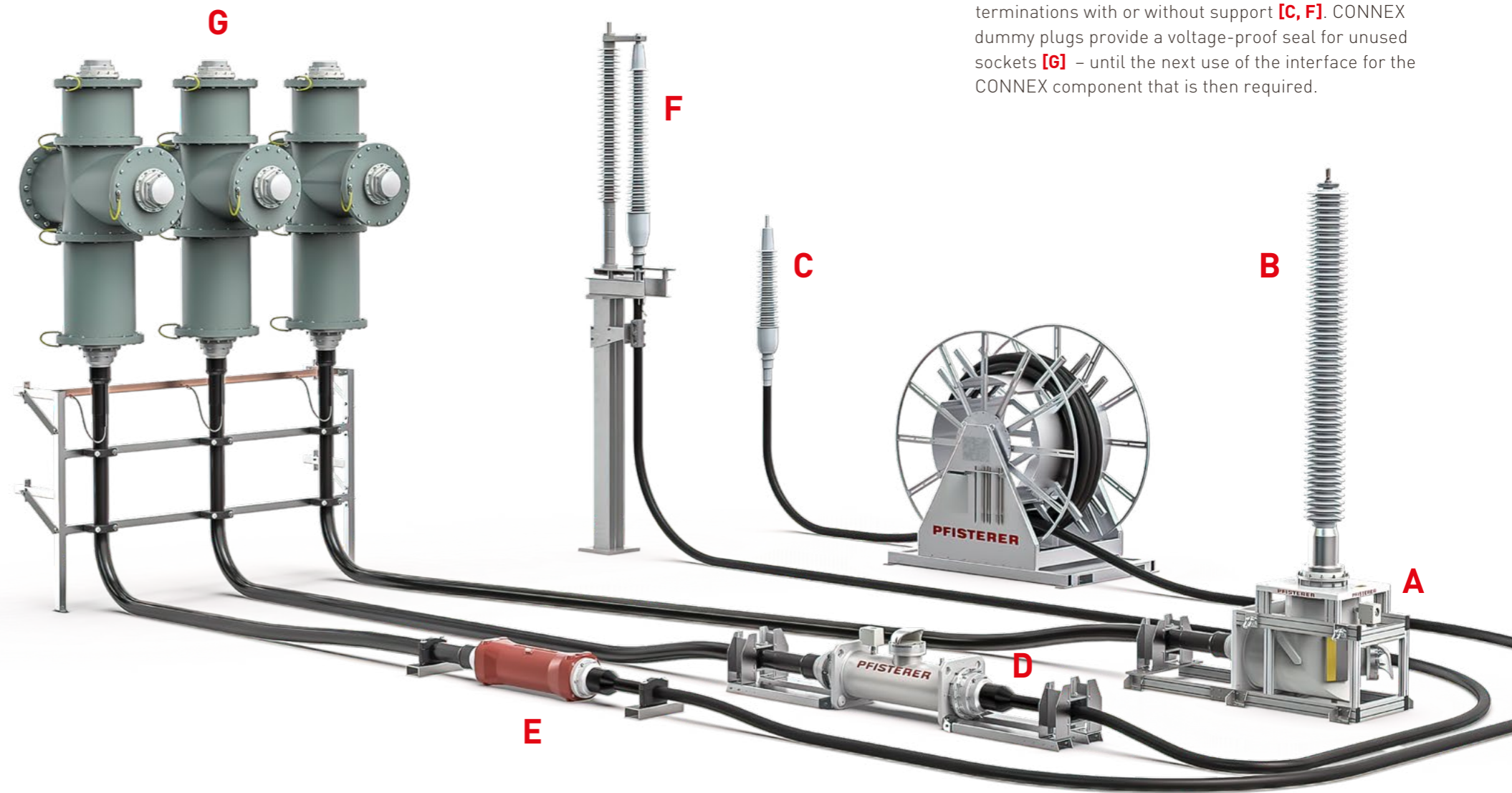

# 4.3 Designing modular equipment. For flexibility and mobility in use.

# 4.3

Safe and secure, lean and flexible – everything that supports the lifelong efficient use of gas-insulated switchgear and transformers in the application examples so far, together meets the requirements for making high voltage equipment mobile economically for various practice-relevant scenarios.

Safe and secure, lean and flexible – everything that supports the lifelong efficient use of gas-insulated switchgear and transformers in the application examples so far, together meets the requirements for making high voltage equipment mobile economically for various practice-relevant scenarios.

Here too, the starting point is the CONNEX system with device-side interfaces for various pluggable CONNEX components for connections, links and protective measures. Their modular interaction makes it possible to flexibilize equipment safely and efficiently for changing locations and connection types occasionally or regularly, for example:

For the **simplest possible relocation of a unit** due to foreseeable changes in the grid topology. Because it has to **move regularly** for bridging during construction work at changing locations. Or as a **versatile reserve in case of emergency** – in a large area with different voltage levels and connection configurations.

**Various sophisticated device and interface concepts have already been successfully realized with CONNEX.** For example, for new types of emergency transformers, extremely compact and lightweight for the fastest possible transportation over long distances, flexibly deployable in different voltage levels. Here the classic design of AC transformers as one unit with three phases

was completely rethought. The result: A modular transformer bank consisting of three single-phase transformers, connected to each other and to the power grid via HV and MV cable solutions with CONNEX plug-in technology. **You can see what other highly flexible solutions can look like in catalog part 3 with more PFISTERER accessories.**

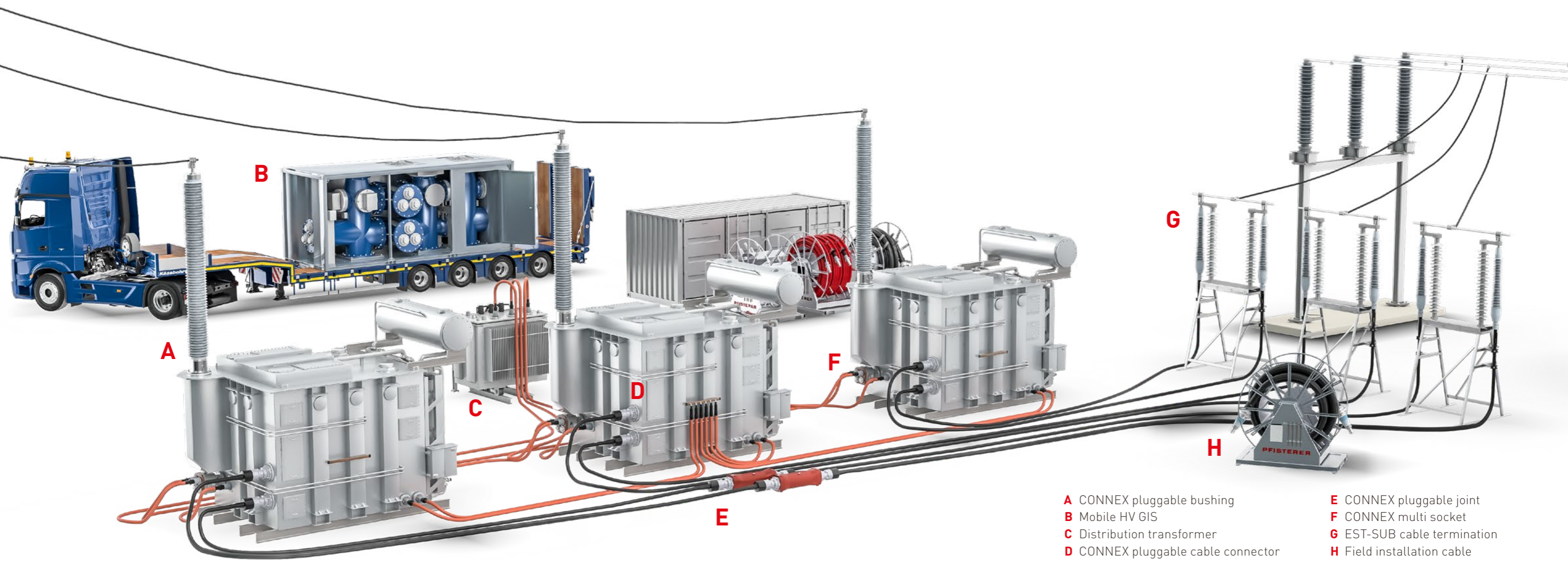

- A CONNEX pluggable bushing
- B Mobile HV GIS
- C Distribution transformer
- D CONNEX pluggable cable connector
- E CONNEX pluggable joint
- F CONNEX multi socket
- G EST-SUB cable termination
- H Field installation cable

## 5.1 Installation know-how for safe initial operation



High voltage places the highest demands on the safety and reliability of systems as well as connecting components and complementary tools. Their quality is not the only deciding factor. Professional installation is equally important – based on practical experience. HV components from PFISTERER are therefore installed exclusively by specialist personnel who have received product-specific training and certification. For the sake of lifelong operational reliability. And also important to maintain the warranty.

To this end, PFISTERER provides comprehensive know-how transfer in practice and theory:

### Installation service

PFISTERER supports you worldwide at regional level with installation services. Provided by our own installation teams or partner firms certified according to strict PFISTERER criteria. With experience of working in a variety of conditions. In a cable trench. In a dry dock. On offshore platforms. With expert knowledge and a precise feel for a wide variety of cable technologies and grounding concepts, all the way to connecting fine fiber optic cables to monitoring boxes. In every situation, competent and efficient in tried-and-tested work steps for safe and professional installation.

### Installation training

For the qualification of your fitters, PFISTERER arranges the obligatory high voltage installation trainings in the company's own training centers worldwide or also individually on your premises.

All training courses include detailed product training as well as requirements, preparations and carrying out the installation with practical exercises and tasks. The training content can be adapted to specific training needs, for example the process of plugging in a CONNEX bushing, cable connector installation in confined spaces with the aid of an assembly cap, or the installation of mobile interim solutions.

Upon successful completion of the course, each participant receives a time-limited certificate. This authorizes them to work independently with the product system they were trained in.

### The standard training courses, which can be extended, include:

- Safety briefing
- General production and application knowledge
- Overview of installation procedure and installation instructions
- Design and components of the accessory
- Cable preparation
- Assembling the accessory on the cable
- Installing the accessory on the equipment or in the cable route, if necessary with grounding system

### Installation instructions

The safe and proper installation of PFISTERER accessories is described in detail with text and illustrations in product-specific installation instructions. They are enclosed with each delivery as part of the product. Each set of instructions must be read in full before starting work, followed step by step, and kept accessible at all times in the immediate vicinity of the product, for example in the control center or switch room.



## 5.2 Engineering expertise for individual solutions



Variably connectable transformers, portable switchgear, mobile substations. Special system applications such as these and others require customized interface solutions. PFISTERER does the work for you – happy to be your highly capable project partner with:

- **Expertise** in the development, design and realization of individual connecting and jointing systems including installation tools and transportation solutions
- **Routine** in interfacing activities between equipment designers, manufacturers and operators
- **Worldwide project experience** with special equipment applications, for example highly compact emergency transformers, through to complete mobile substations for large-scale grid remodelings



This QR code will take you to exemplary projects with customized PFISTERER solutions.

Would you like support with your project?  
Email us at [info@pfisterer.com](mailto:info@pfisterer.com).  
We are looking forward to your project!

### Issue 1-2024

#### PFISTERER editorial team

Peter Arranz, Katrin Brecht, Simon Brendel, Andreas Dobler, Alejandro Escobin, Natalie Fischer, Thomas Friedel, Marcel Heckel, Maximilian Kraus, Thorsten Ludwig, Stephan Marx, Wadim Mirau, Eduardo Santana, Frank Straßner, Frank Weichert

#### Content conception and text editing

Karolina Kos, xyzeiler.de

#### Art direction and visual design

David Kaiser, DaKa.design

#### Disclaimer and copyright

The catalog contents have been compiled and checked with care. No liability is assumed for any inaccuracies or errors. We reserve the right to make changes due to updates. All catalog contents are protected by copyright. Copies in whole or in part require the written permission of PFISTERER.

© PFISTERER Holding SE

PFISTERER Holding SE

Rosenstraße 44  
73650 Winterbach  
Germany  
Phone: +49 7181 7005 0  
Fax: +49 7181 7005 565  
info@pfisterer.com  
www.pfisterer.com

PFISTERER is a globally leading and independent technology company with head offices in Winterbach near Stuttgart, Germany. We develop, produce and sell technology for insulating and connecting electrical conductors for power grid interfaces - from the generation and transmission to the distribution of electrical energy. With state-of-the-art production facilities, high quality standards, and technological expertise, we contribute to a safe and reliable energy supply for the future.